

Cargo Elevator/ Car Elevator

载货电梯/汽车电梯

西尼机电（杭州）有限公司
Syney Electric (Hangzhou) Co.,Ltd.

24小时服务热线 **4008-267-608**
24-Hour Service Hotline

Web: www.syney.net

地址: 浙江省杭州市萧山区南阳经济开发区阳城路31号

Address: No.31 Yangcheng Road, Nanyang Economic Development Area,
Xiaoshan District, Hangzhou, Zhejiang, China.

⚠ 注意事项

安装、改造、维修和电梯日常维护保养的施工单位，必须取得《特种设备安装改造维修许可证》，并在许可的范围内从事相应工作。电梯日常维护保养单位必须取得电梯维修的资格许可。

对人员的要求：机械或者电气工程师，持特种设备上岗操作证。

⚠ Attention

The construction units who are in charge of installation, modernization, repair and regular maintenance must obtain 'Installation, Alteration, Repair & Maintenance License of Special Equipment' and only do corresponding works in accordance with work permission range. Elevator regular maintenance construction units must obtain elevator maintenance permission license.

Personnel requirement: mechanical or electrical engineers, with special equipment operation certificate.

本书为一般信息类出版物，我们保留随时更改产品设计和说明的权利。
本书的任何字句，无论字面意思或含义，对于任何产品及该产品的用途和质量，或者任何购销合同条款的表述与更改均不承担任何责任。
由于印刷工艺的限制，实际加工的颜色可能与本册略有不同，最终选型可根据实际材料和色样决定。

This catalog is just regular information publication; we reserve the right to revise product design and explanation at any time.
We bear no responsibility on any words or meanings in this catalog, for any product or its usage and quality description, or any sales contract.
Due to the printing process limitations, the actual color might be different from the catalog. Final model shall refer to real material and color.

XN-021-04

我们的产品与您的建筑物同在
Our Product Is The Best Option For Your Buildings

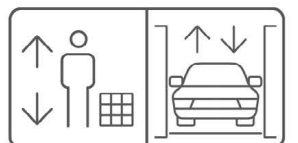



Syney Brand

品牌缘起

1963

Friedrich Sylva先生和Hoffman Gaultney先生在北莱茵-威斯特法伦州的波恩Bonn创建了Syney bautechnische Beratung GmbH公司——即今天德国Syney (西尼) 公司的前身; 作为战后联邦德国城市规划的重要阶段, 当时的Syney公司专注建筑技术解决方案领域, 为当时的德国城市重建提供了自己的力量。近60年来, 德国西尼 (Syney) 品牌以其先进且不断进取的研发技术, 持续在电梯技术、建筑技术、环境节能优化技术等方面在欧洲一直保持领先地位。

Syney Germany was formerly known as Syney Bautechnische Beratung GmbH founded by Mr. Friedrich Sylva and Mr. Hoffman Gaultney in Bonn, North Rhine-Westphalia. To support federal Germany in post-war urban reconstruction and urban planning, Syney was then dedicated to exploring building technology solutions. During the past 60 years, Syney persevered in R&D of advanced technology and has always been a leading player in Europe in fields of elevator technology, building technology and energy saving and optimization technology.

2003

基于对中国市场的战略布局, 德国Syney (西尼) 公司和中国的合作伙伴在杭州成立了西尼电梯 (杭州) 有限公司, 致力于为中国客户提供垂直客流及水平客流解决方案。

Based on the strategic planning of Chinese market, Syney cooperated with Chinese partner to establish Syney Elevator (Hangzhou) Co., Ltd., committed to providing Chinese customers with solutions to vertical and horizontal people flow transport.

2013

基于德国西尼集团品牌发展及整体战略规划, Syney Technologie (Deutschland) GmbH正式升级更新为Syney GmbH; 同时将亚太区的电梯技术业务全部转让给中国的合作伙伴, 西尼电梯 (杭州) 有限公司正式拥有德国Syney在中国的所有电梯技术专利权及Syney品牌在亚太区的所有权。

Based on the brand development and overall strategic planning, Syney Technologie (Deutschland) GmbH was officially upgraded to Syney GmbH; furthermore, elevator technology business in Asia-Pacific region got fully transferred to Chinese partner. Syney Elevator (Hangzhou) Co., Ltd. became the legal owner of Syney's all elevator technology patents in China and Syney brand in Asia-Pacific region.

未来 Future

Syney (西尼) 愿与广大合作伙伴一起, 以完美的建筑人流输送解决方案为中国带来更好品质的产品、技术和服, 建立理想人居舒适生活的新标准。

Syney is willing to join hands with our partners to explore optimal solutions to passenger transport in and between buildings, provide Chinese customers with the best products, technology and services, and establish new standard of ideal and comfortable living style.

西尼机电 (杭州) 有限公司是一家集研发设计、制造、销售、安装、服务于一体的电梯企业。公司全套采用高新技术, 专业从事乘客电梯、观光电梯、无机房电梯、病床电梯、载货电梯、自动扶梯、自动人行道、家用电梯、汽车电梯等多种产品的设计与制造、依靠先进的技术、现代化的设备、标准化管理、精准的品牌定位和完善的营销服务网络, 西尼机电业务稳步提升, 产品销售网络覆盖全国, 是中国最具发展力的电梯企业之一。

Syney Electric (Hangzhou) Co., Ltd. is a professional elevator company integrating R&D, manufacture, sales, installation and service. With full set of high technologies, Syney specializes in the design and manufacture of many products including passenger elevator, panoramic elevator, MRL elevator, bed elevator, cargo elevator, escalator, moving walk, villa elevator, car lift, etc. Depending on advanced technologies, modern equipment, standardized management, precise brand positioning and perfect marketing & service network, Syney business keeps steady growth and the sales network extends to the whole country. Syney Electric (Hangzhou) Co., Ltd. has been one of the most competitive elevator companies in China.



50

出口到欧洲、亚洲、非洲、美洲等50多个国家和地区

The products have been exported to over 50 countries and regions in Europe, Asia, Africa and America.



5

公司注册资本5亿元

The registered capital is RMB500 million



99000

占地面积99000平方米

It covers an area of 99,000 m²

适用范围

Scope & Requirements

具有安全可靠、结构强度高、经久耐用、运行平稳、开门距大等优点,成为工厂、仓库、商场、物流中心、会展中心等运输货物需求的理想选择,并可在各种恶劣环境下进行运输工作。

With advantages of being safe and reliable, high structure strength, enduring, smooth running and wide open width etc., Syney cargo elevator is becoming the perfect choice to transport goods in factory, warehouse, shopping mall, logistic center and exhibition center etc., and able to work under any strict working condition.



有机房载货电梯 MR Cargo Elevator

适用于 Applicable to

- 中低层楼宇
Low and medium rise buildings

产品使用范围 Production Range of Application

- 提升高度≤50m
Rising height ≤ 50m
- 额定载重≤7000kg
Rated capacity ≤ 7000Kg

无机房载货电梯 MRL Cargo Elevator

适用于 Applicable to

- 中低层楼宇
Low and medium rise buildings

产品使用范围 Production Range of Application

- 提升高度≤50m
Rising height ≤ 50m
- 额定载重≤3000kg
Rated capacity ≤ 3000Kg

有机房汽车电梯 MR Car Elevator

适用于 Applicable to

- 地下停车场
Underground garage
- 立体车库
Parking system

产品使用范围 Production Range of Application

- 提升高度≤25m
Rising height ≤ 25m
- 额定载重≤5000kg
Rated capacity ≤ 5000Kg
- 详情参考P5页
See page P5 for details

Application range & Load type

使用范围及载荷类型



Wide Application with Ride Stability and Comfort

平稳舒适 使用广泛

先进的矢量控制技术, 电机调速性能优, 提高乘坐舒适性。直接停靠技术, 提高电梯运行效率。
Advanced vector control technology, excellent motor speed regulation performance, improve ride comfort. Direct parking technology, improve the efficiency of elevator operation.

预转矩启动技术, 使电梯的启动更加平稳。
The pre torque starting technology makes the elevator start more stable.

控制器结构紧凑, 驱动器采用先进第6代PIM模块, 模块耐高温 (175°C)。
The controller structure is compact and drivers adopts 6th generation PIM module, which endures high temperature to 175°C.

双32位嵌入式微处理芯片共同完成电梯控制功能和电机驱动控制, 可持续重载运行, 更加平稳, 兼具减震、降低电磁噪音。
Dual 32 bits embedded micro-processing chips fulfill elevator function and motor drive controls together, which enable the elevator to run continuously with heavy load, be steadier and more smooth with shock absorption and reduces electromagnetic noise.

Load type

载荷分类

电梯使用的场合不同, 承载的类型也不同。
Different elevator applications, different load type.

A类载荷

由手工或借助于轻型手推车装卸, 货物均匀地分布在轿底上, 不得集中轿底任何一特殊一点上, 例如在某一角上, 单件货物重量不得超过电梯额定载重的25%。
The goods shall be evenly distributed on the car platform by manual loading and unloading or with the help of small trolley. Goods centralization at any single special points on the car platform is not allowed, like at certain corner, single goods weight shall not be more than 25% of rated load capacity.

B类载荷

仅供汽车电梯
For car only.

C类载荷

工业搬运车载荷, 搬运车可以随电梯运输, 装卸过程中搬运工具及货物总重不允许超过电梯额定载荷。
Industrial truck transportation, at which carrier can be transported along with elevator, the overall goods weight together with the carrier weight shall not exceed elevator rated load capacity.

注意:
购买产品时请注意选择合适的额定载重和载荷类型(A、B、C)。对于超载或未遵照载荷类型运载货物等不当使用行为而产生的问题, 均不属于西尼机电责任范畴。
Note:
Please select appropriate rated load and load type (A/B/C) when placing the order. We are not being responsible for any problems caused by overload or improper operations not following load type.

适用环境及载荷类型 (Applicable range & Load type)

Type 型号	Load 载重量 (Kg)	Rated Speed 额定速度 V(m/s)	Application 适用环境	Travel Height(Max) 运行高度 (最大) TH(m)	Max No. of Stops 最大停站数	Load Type 载荷分类
Cargo Elevator 载货电梯	1000	0.25	Logistics / Exhibition Center 物流/会展中心	TH≤12	5	A
	2000					A
	3000					A
	4000					A、C
	5000					A、C
	7000					A、C
	1000	0.5	Factory / warehouse 工厂/仓库	TH≤25	8	A
	2000					A
	3000					A
	4000					A、C
	5000					A、C
	7000					A、C
Car Elevator 汽车电梯	1000	1.0	Shopping malls / supermarkets 商场/超市	TH≤50	16	A
	2000					A
	3000					A
Car Elevator 汽车电梯	3000	0.5	Automobile service shop 4S / Underground garage 汽车4S店/地下停车场	TH≤25	8	B
	5000			TH≤12		

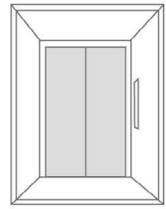

Cabin 轿厢

Cargo Elevator
载货电梯



21H001

- 吊顶: 钢板喷涂+筒灯+风扇
Ceiling: Painted Steel Plate+Downlight+Fan
- 轿壁: 钢板喷涂
Car Wall: Painted Steel Plate
- 地坪: 防滑花纹钢板
Flooring: Anti-skid Checkered Steel Plate
- 前壁: 钢板喷涂
Front Wall: Painted Steel Plate
- 轿门: 钢板喷涂
Car Door: Painted Steel Plate

防撞条装置(可选)
Bumper Strip(Optional)

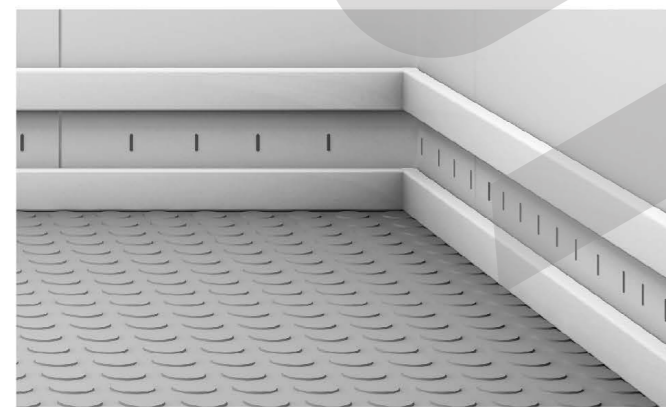

厅门
Landing Door



吊顶
Ceiling

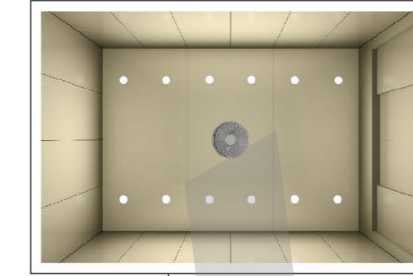

轿壁(可选)
Car Wall(Optional)



召唤盒(可选)
HOP(Optional)



操纵箱
COP



地坪(可选)
Flooring(Optional)



吊顶照明色温 Ceiling Light Color Temperature	3000K		4200K		6500K	
	○	○	○	○	●	●
载货电梯载重 Cargo Elevator Load Capacity	1000KG	2000KG	3000KG	4000KG	5000KG	7000KG
汽车电梯载重 Car Elevator Load Capacity	3000		5000		5000	
最佳高度 Optimal Height	2300	2300	2300	2300	2300	2300
最大高度 Max. Height	2800	2800	2800	2800	2800	2800

Syney Brand
品牌源起
Application Range
范围
Cabin Design
轿厢设计
Decoration Parts
装潢部件
Safety and Comfort
安全舒适
Layout drawing
土建图

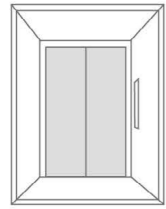

Cabin

轿厢

Cargo Elevator
载货电梯

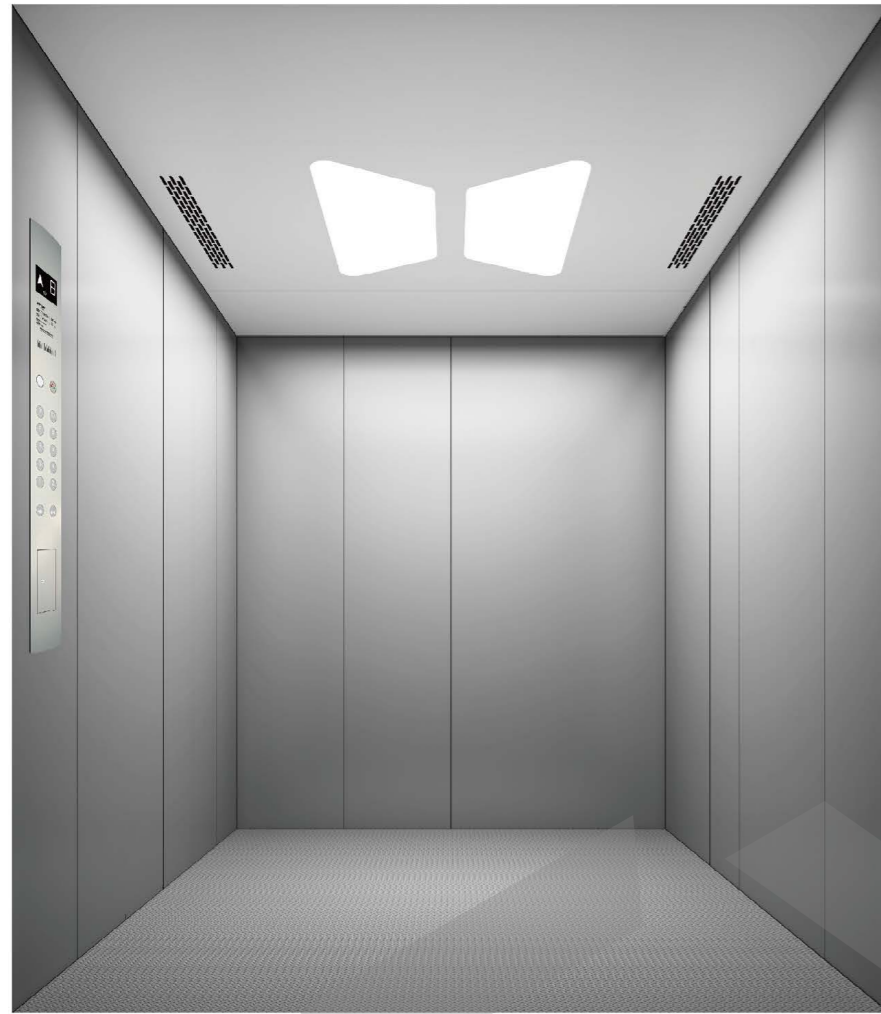
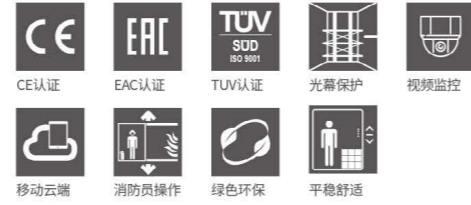

21H002

- 吊顶: 钢板喷涂+亚克力+LED照明
Ceiling: Painted Steel Plate+Acrylic+LED light
- 轿壁: 钢板喷涂
Car Wall: Painted Steel Plate
- 地坪: 防滑花纹钢板
Flooring: Anti-skid Checkered Steel Plate
- 前壁: 钢板喷涂
Front Wall: Painted Steel Plate
- 轿门: 钢板喷涂
Car Door: Painted Steel Plate

防撞条装置(可选)
Bumper Strip(Optional)

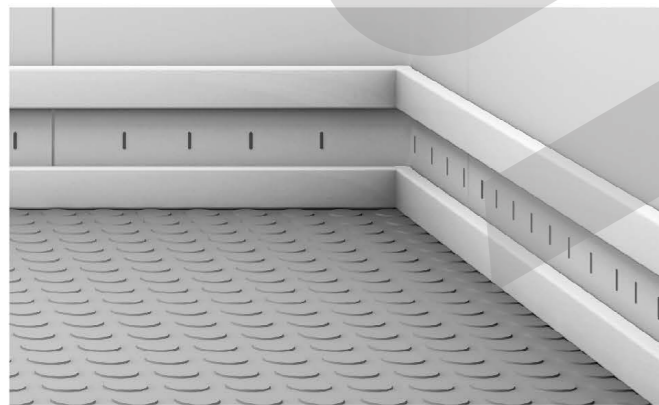

厅门
Landing Door



吊顶
Ceiling

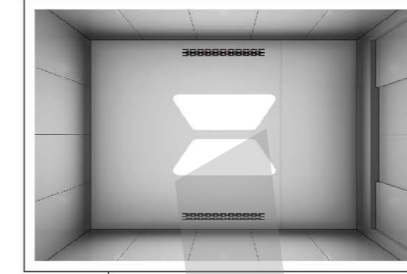

轿壁(可选)
Car Wall(Optional)



召唤盒(可选)
HOP(Optional)



操纵箱
COP

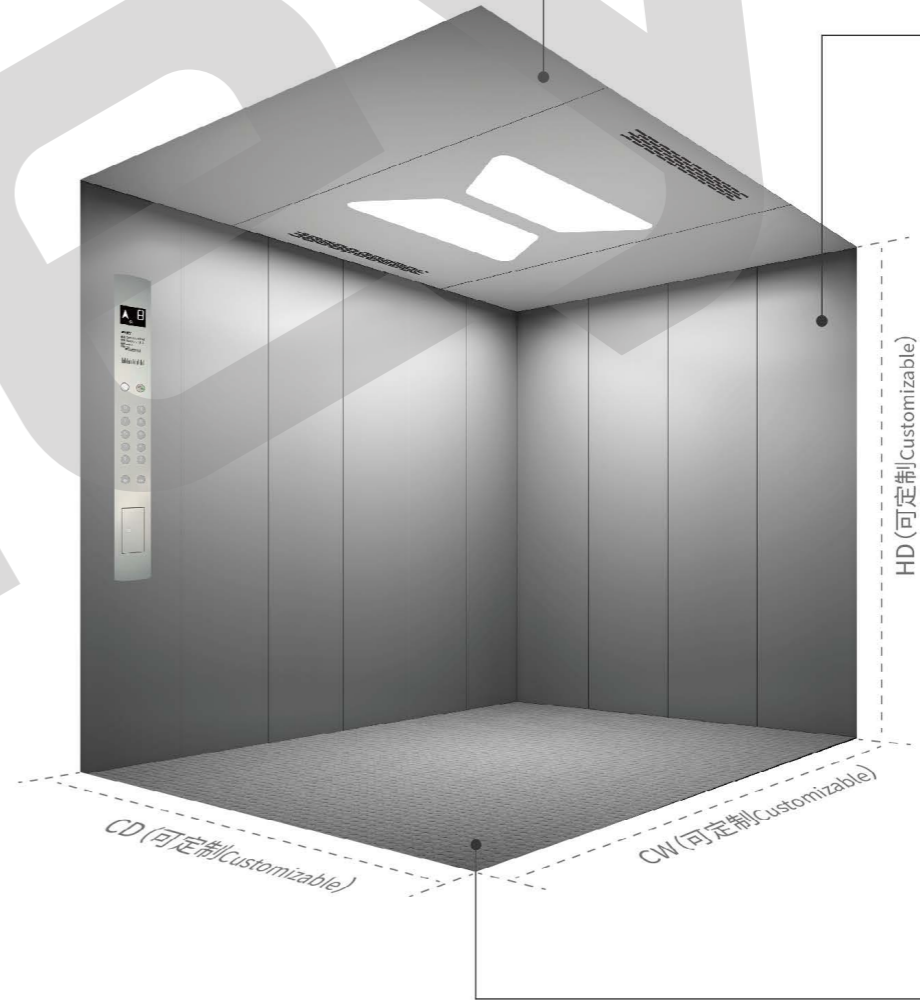

地坪(可选)
Flooring(Optional)



吊顶照明色温 Ceiling Light Color Temperature	3000K		4200K		6500K	
	○	○	○	○	●	●
载货电梯载重 Cargo Elevator Load Capacity	1000KG	2000KG	3000KG	4000KG	5000KG	7000KG
汽车电梯载重 Car Elevator Load Capacity		3000			5000	
最佳高度 Optimal Height	2300	2300	2300	2300	2300	2300
最大高度 Max. Height	2800	2800	2800	2800	2800	2800

Syneer Brand
品牌源起

Application Range
范围

Cabin Design
轿厢设计

Decoration Parts
装饰部件

Safety and Comfort
安全舒适

Layout drawing
土建图

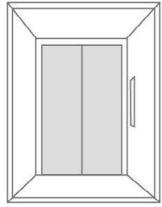

Cabin

轿厢

Cargo Elevator
载货电梯

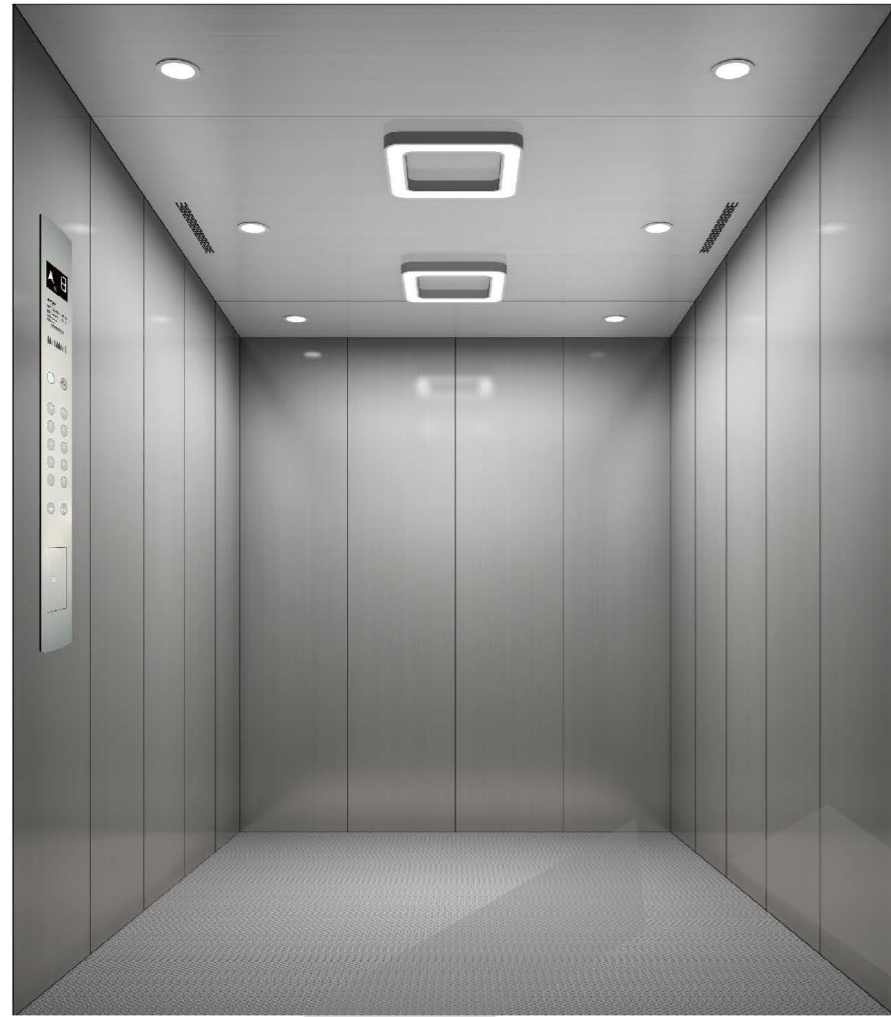

21H003

- 吊顶: 发纹不锈钢+筒灯+装饰灯
Ceiling: Hairline St.St.+Downlight +Decorative Light
- 轿壁: 发纹不锈钢
Car Wall: Hairline St.St.
- 地坪: 防滑花纹钢板
Flooring: Anti-skid Checkered Steel Plate
- 前壁: 发纹不锈钢
Front Wall: Hairline St.St.
- 轿门: 发纹不锈钢
Car Door: Hairline St.St.

防撞条装置(可选)
Bumper Strip(Optional)

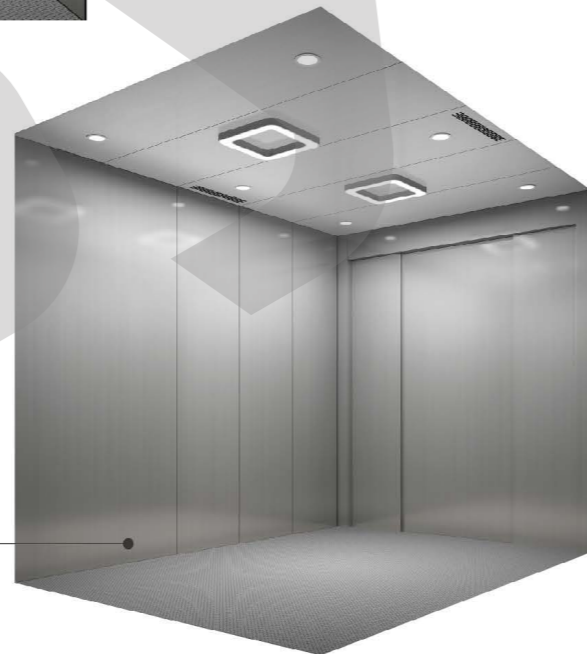
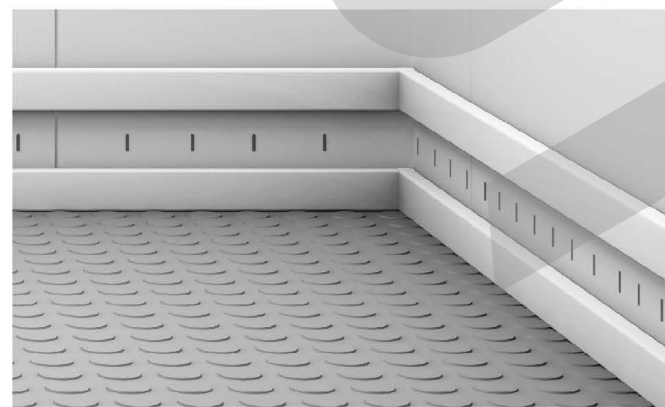

厅门
Landing Door



吊顶
Ceiling

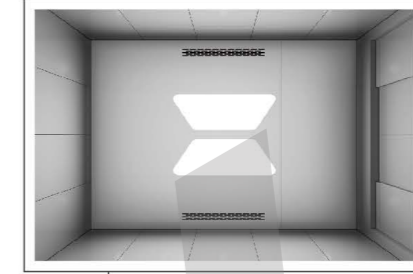

轿壁(可选)
Car Wall(Optional)



召唤盒(可选)
HOP(Optional)



操纵箱
COP



地坪(可选)
Flooring(Optional)



吊顶照明色温 Ceiling Light Color Temperature	3000K		4200K		6500K	
	○	○	○	○	●	●
载货电梯载重 Cargo Elevator Load Capacity	1000KG	2000KG	3000KG	4000KG	5000KG	7000KG
汽车电梯载重 Car Elevator Load Capacity		3000			5000	
最佳高度 Optimal Height	2300	2300	2300	2300	2300	2300
最大高度 Max. Height	2800	2800	2800	2800	2800	2800

Syneer Brand
品牌源起

Application Range
范围

Cabin Design
轿厢设计

Decoration Parts
装饰部件

Safety and Comfort
安全舒适

Layout drawing
土建图

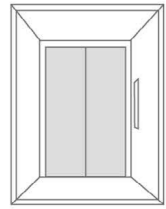

Cabin

轿厢

Cargo Elevator
载货电梯

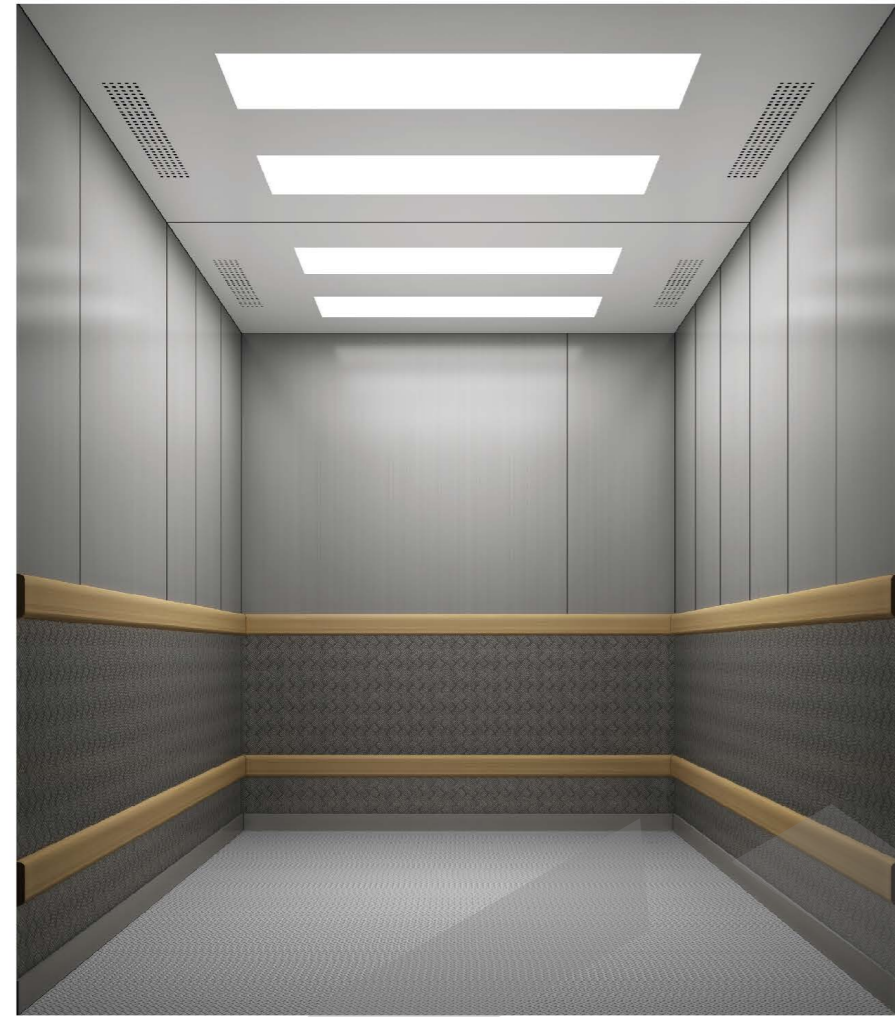

21H004

- 吊顶: 钢板喷涂+亚克力+LED照明
Ceiling: Painted Steel Plate+Acrylic+LED light
- 轿壁: 发纹不锈钢+防滑钢板+实木防撞护栏
Car Wall: Hairline St.St.+Anti-skid Steel Plate+Wood Guardrail
- 地坪: 防滑花纹钢板
Flooring: Anti-skid Checkered Steel Plate
- 前壁: 发纹不锈钢
Front Wall: Hairline St.St.
- 轿门: 发纹不锈钢
Car Door: Hairline St.St.

无防撞条装置(可选)
Bumper Strip(Optional)

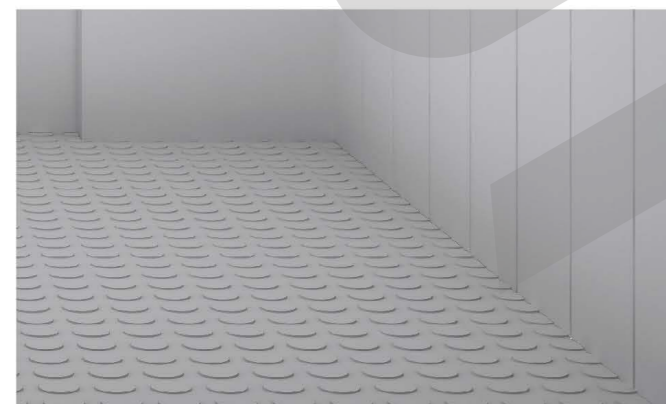

厅门
Landing Door



吊顶
Ceiling

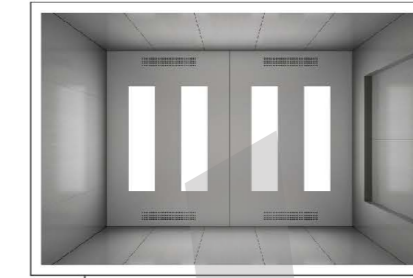

轿壁(可选)
Car Wall(Optional)



召唤盒(可选)
HOP(Optional)



操纵箱
COP



地坪(可选)
Flooring(Optional)



吊顶照明色温 Ceiling Light Color Temperature	3000K		4200K		6500K	
	○	○	○	○	●	●
载货电梯载重 Cargo Elevator Load Capacity	1000KG	2000KG	3000KG	4000KG	5000KG	7000KG
汽车电梯载重 Car Elevator Load Capacity		3000			5000	
最佳高度 Optimal Height	2300	2300	2300	2300	2300	2300
最大高度 Max. Height	2800	2800	2800	2800	2800	2800

Syney Brand
品牌源起

Application Range
范围

Cabin Design
轿厢设计

Decoration Parts
装潢部件

Safety and Comfort
安全舒适

Layout drawing
土建图

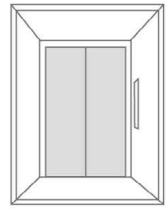

Cabin 轿厢

Cargo Elevator
载货电梯

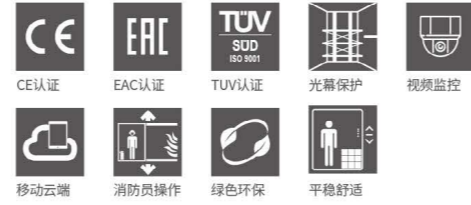

21H005

- 吊顶: 钢板喷涂+筒灯+风扇
Ceiling: Painted Steel Plate+Downlight+Fan
- 轿壁: 钢板喷涂
Car Wall: Painted Steel Plate
- 地坪: 防滑花纹钢板
Flooring: Anti-skid Checkered Steel Plate
- 前壁: 钢板喷涂
Front Wall: Painted Steel Plate
- 轿门: 钢板喷涂
Car Door: Painted Steel Plate

防撞条装置(可选) Bumper Strip(Optional)

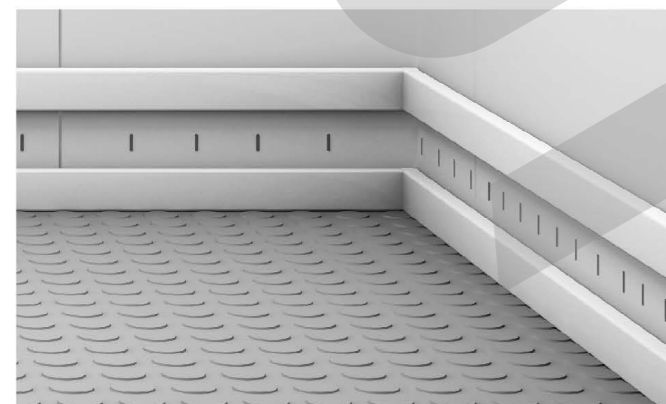

厅门 Landing Door



吊顶 Ceiling

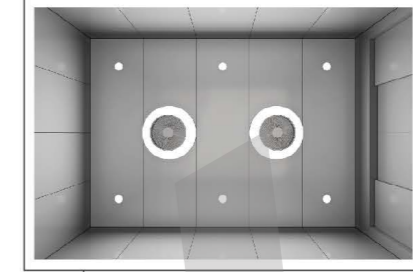

轿壁(可选) Car Wall(Optional)



召唤盒(可选) HOP(Optional)



操纵箱 COP



地坪(可选) Flooring(Optional)



吊顶照明色温 Ceiling Light Color Temperature	3000K		4200K		6500K	
	○	○	○	○	●	●
载货电梯载重 Cargo Elevator Load Capacity	1000KG	2000KG	3000KG	4000KG	5000KG	7000KG
汽车电梯载重 Car Elevator Load Capacity		3000			5000	
最佳高度 Optimal Height	2300	2300	2300	2300	2300	2300
最大高度 Max. Height	2800	2800	2800	2800	2800	2800

Syneer Brand
品牌源起

Application Range
范围

Cabin Design
轿厢设计

Decoration Parts
装潢部件

Safety and Comfort
安全舒适

Layout drawing
土建图

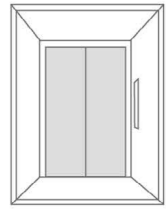

Cabin

轿厢

Cargo Elevator
载货电梯

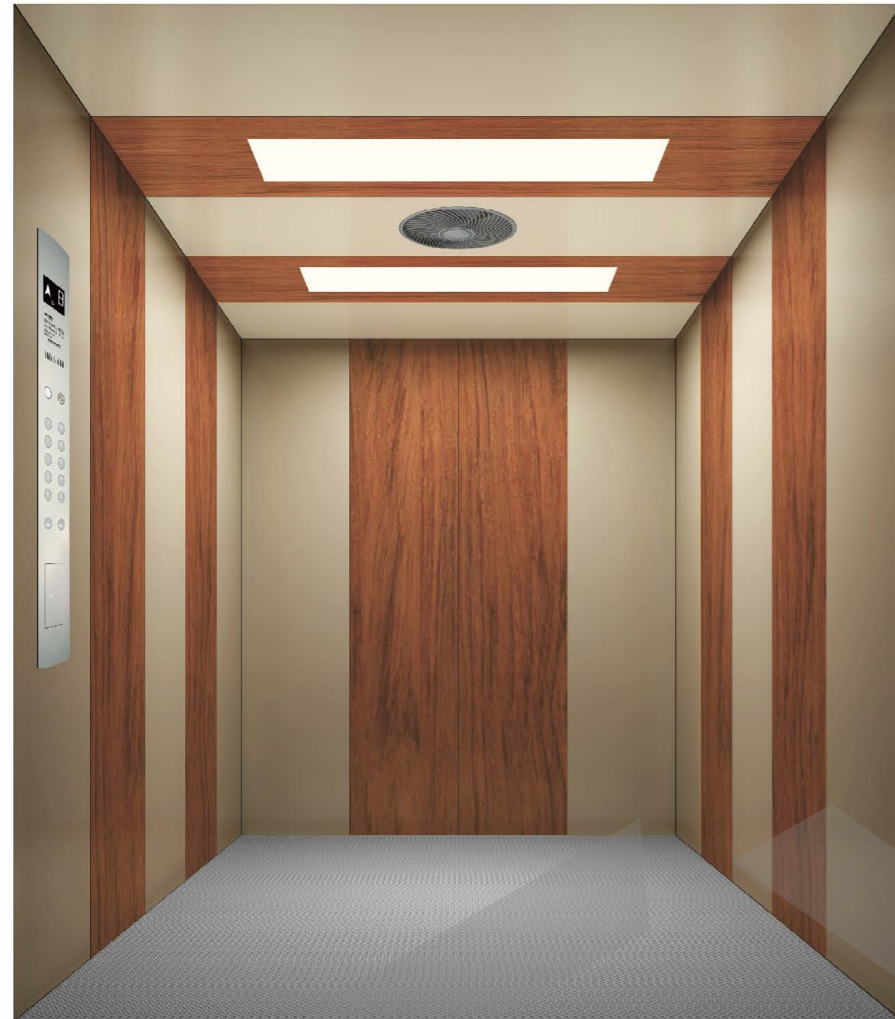

21H006

- 吊顶: 彩涂钢板+木纹化妆钢板+亚克力+LED照明
 Ceiling: Colored Drawing Steel Plate+Wood Grain Steel Plate+Acrylic+LED light
- 轿壁: 彩涂钢板+木纹化妆钢板
 Car Wall: Colored Drawing Steel Plate+Wood Grain Steel Plate
- 地坪: 防滑花纹钢板
 Flooring: Anti-skid Checkered Steel Plate
- 前壁: 彩涂钢板
 Front Wall: Colored Drawing Steel Plate
- 轿门: 彩涂钢板
 Car Door: Colored Drawing Steel Plate

防撞条装置(可选) Bumper Strip(Optional)

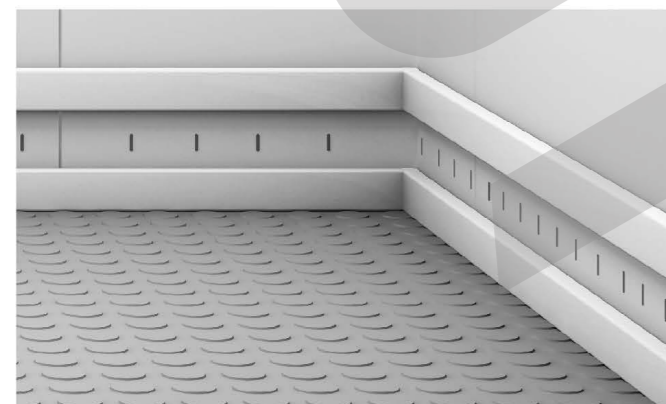

厅门 Landing Door



吊顶 Ceiling



轿壁(可选) Car Wall(Optional)



召唤盒(可选) HOP(Optional)



操纵箱 COP



地坪(可选) Flooring(Optional)



吊顶照明色温 Ceiling Light Color Temperature	3000K		4200K		6500K	
	○	○	○	○	●	●
载货电梯载重 Cargo Elevator Load Capacity	1000KG	2000KG	3000KG	4000KG	5000KG	7000KG
汽车电梯载重 Car Elevator Load Capacity	3000		5000		5000	
最佳高度 Optimal Height	2300	2300	2300	2300	2300	2300
最大高度 Max. Height	2800	2800	2800	2800	2800	2800

Syney Brand
品牌源起

Application Range
范围

Cabin Design
轿厢设计

Decoration Parts
装潢部件

Safety and Comfort
安全舒适

Layout drawing
土建图

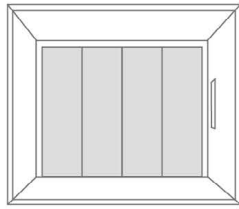

Cabin 轿厢

Car Elevator
汽车电梯

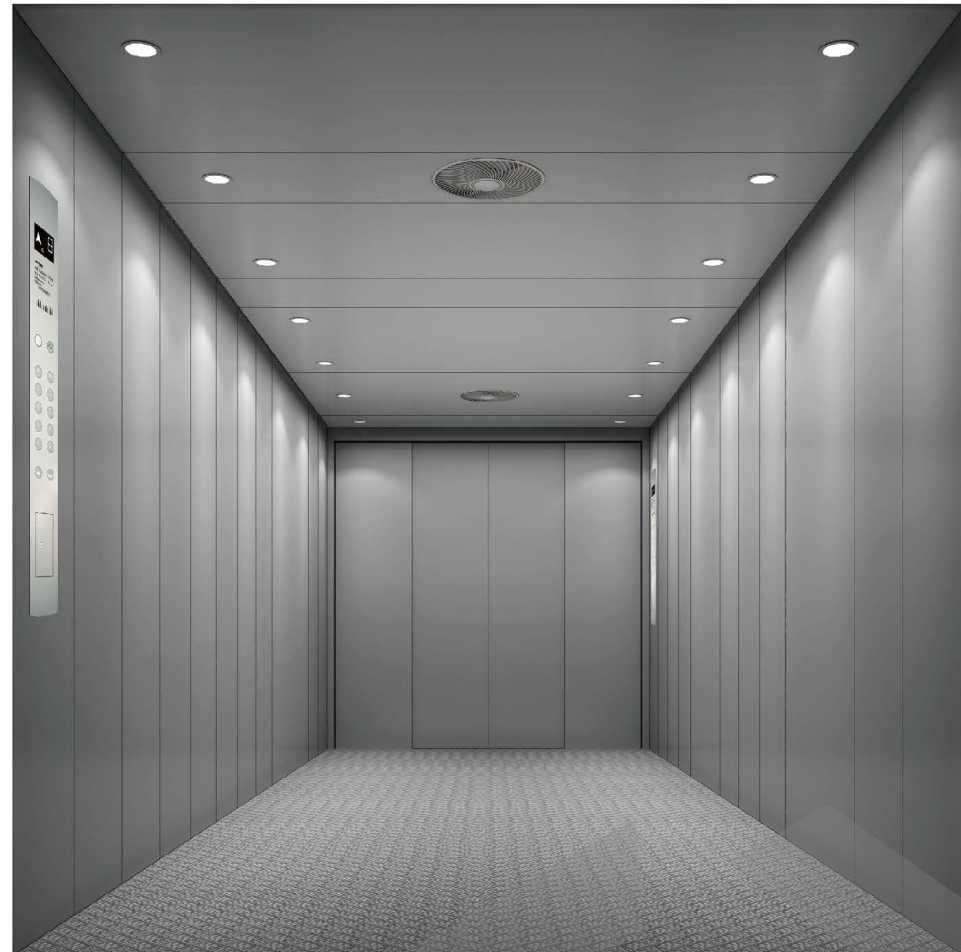
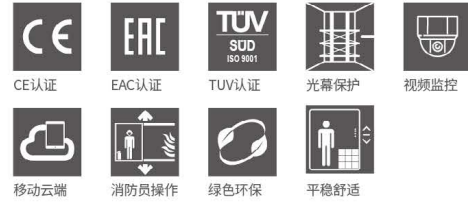

SYNEY系列汽车电梯采用国际先进的电梯技术,充分保障了对于汽车产品的大体积、大载重需求,使汽车出入更加安全可靠,可广泛应用于停车场、汽车4S店、修理厂、地下车库等场所。

Syney car elevator series adopt international advanced technology, fully guarantee the demand for large volume, heavy load of automobile products, make it safer and more reliable for car to go in and out, which can be widely applied to parking lot, automobile 4S shop, repair shop, and underground garage etc.

21Q001

- 吊顶: 钢板喷涂+筒灯+风扇
Ceiling: Painted Steel Plate+Downlight+Fan
- 轿壁: 钢板喷涂
Car Wall: Painted Steel Plate
- 地坪: 防滑花纹钢板
Flooring: Anti-skid Checkered Steel Plate
- 前壁: 钢板喷涂
Front Wall: Painted Steel Plate
- 轿门: 钢板喷涂
Car Door: Painted Steel Plate

汽车尺寸示例:
Example of car size:

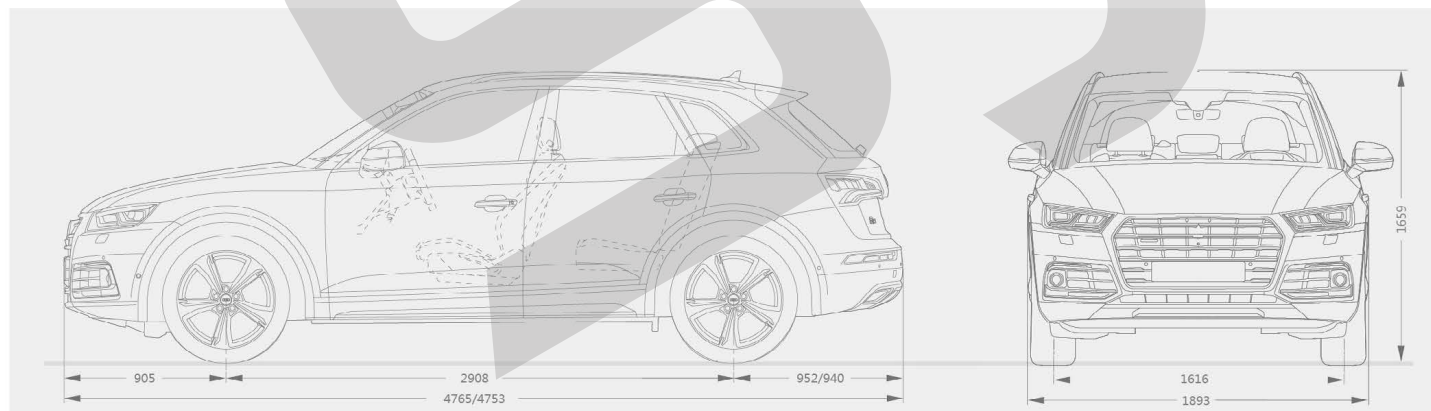

此为某品牌SUV,尺寸仅供参考。 Car size (one SUV brand) is only for reference.

厅门
Landing Door



吊顶
Ceiling

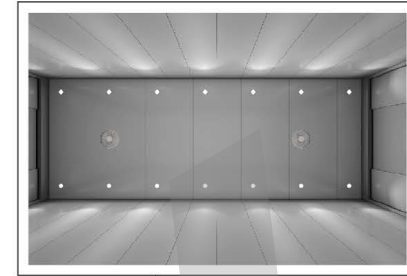

轿壁(可选)
Car Wall(Optional)



召唤盒(可选)
HOP(Optional)



操纵箱
COP



地坪(可选)
Flooring(Optional)

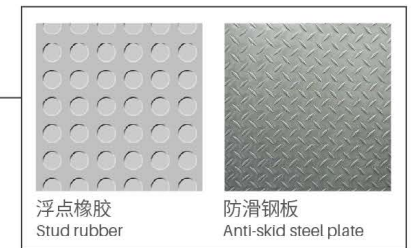

吊顶照明色温 Ceiling Light Color Temperature	3000K		4200K		6500K	
	○	○	○	○	●	●
载货电梯载重 Cargo Elevator Load Capacity	1000KG	2000KG	3000KG	4000KG	5000KG	7000KG
汽车电梯载重 Car Elevator Load Capacity	3000				5000	
最佳高度 Optimal Height	2300	2300	2300	2300	2300	2300
最大高度 Max. Height	2800	2800	2800	2800	2800	2800

Syney Brand
品牌源起

Application Range
范围

Cabin Design
轿厢设计

Decoration Parts
装潢部件

Safety and Comfort
安全舒适

Layout drawing
土建图



COP

操纵箱

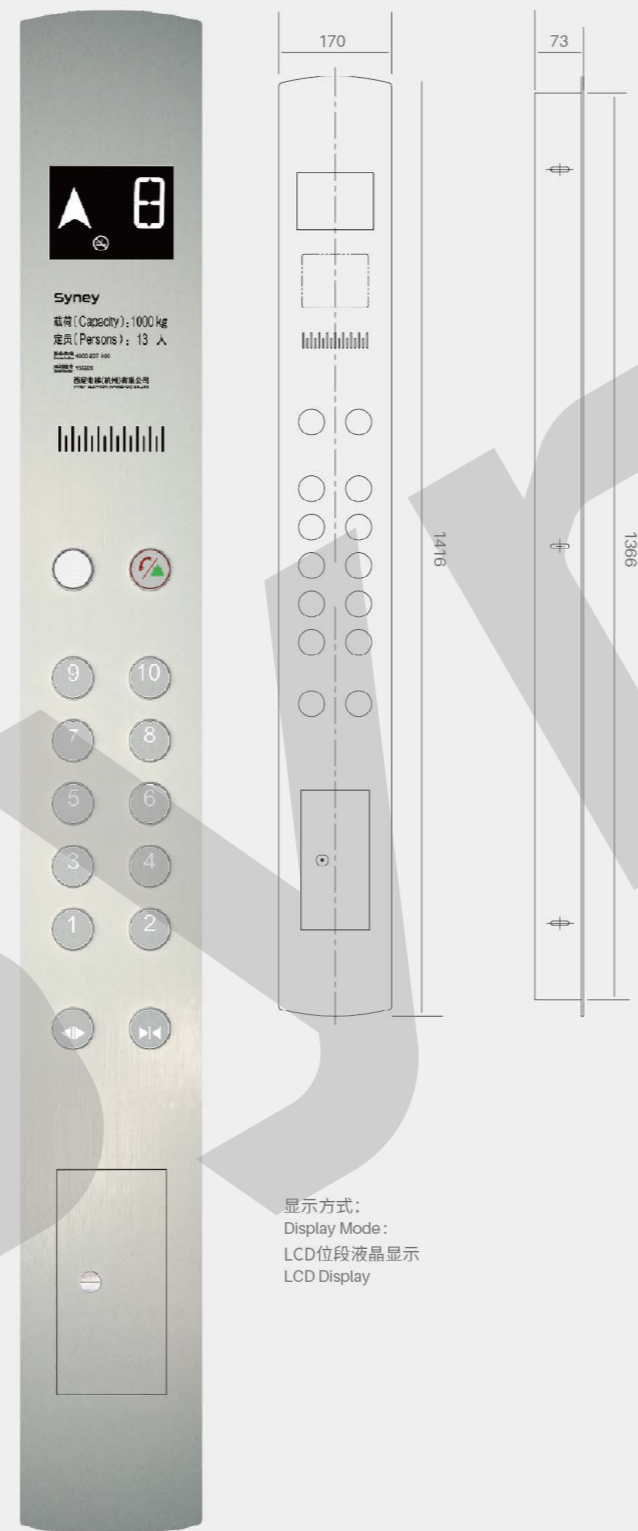

21CZ001

HOP

召唤盒

Customizable according to users' needs
根据使用方需求定制

Focusing on practicability and convenience, perfectly
blend functions into overall solutions
关注实用性和便捷性,将功能完美融合到整体方案中

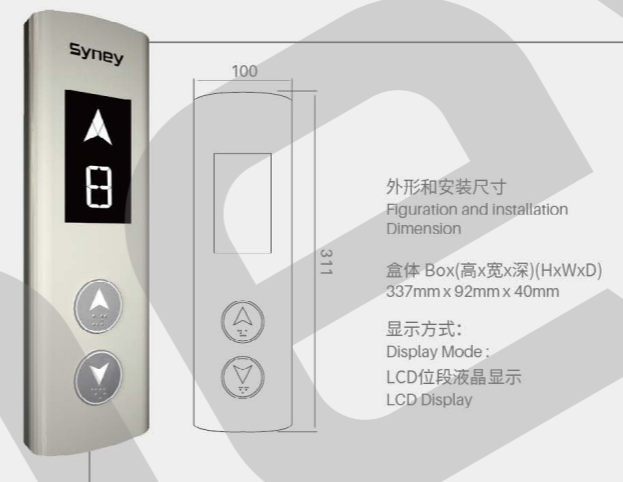
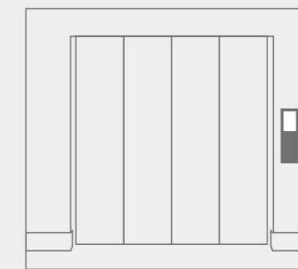

21ZH001 | 选配 Optional

外挂式召唤盒
Surface mounted
calling box



21ZH002 | 选配 Optional

埋入式召唤盒
Embedded
calling box



21ZH009

外挂式召唤盒
Surface mounted
calling box



21ZH010

外挂式召唤盒
Surface mounted
calling box

备注:

- 面板由不锈钢+有机玻璃组合;
- 面板处理有发纹、镜面、钛金镜面、钛金发纹等;

Note:

- Panel made up of stainless steel+laminated glass
- Options: hairline, mirror, titanium mirror, titanium hairline etc.

Cabin Wall 轿厢壁材质选择



灰色不锈钢
Gray stainless steel



发纹不锈钢
Hairline stainless steel



喷涂钢板
Painted steel plate

Cabin Floor 轿厢地坪

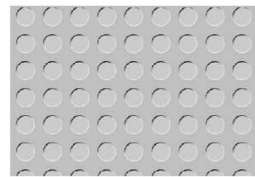

浮点橡胶
Stud rubber



PVC地坪
PVC

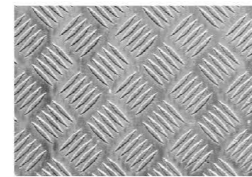

防滑钢板
Anti-skid steel plate

Standard Colour 标准色卡

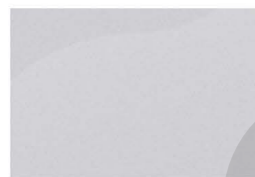

珍珠银
Pearl silver



珍珠金
Pearl gold

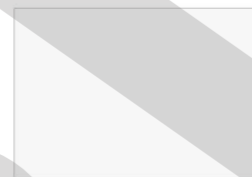

珍珠白
Pearl white

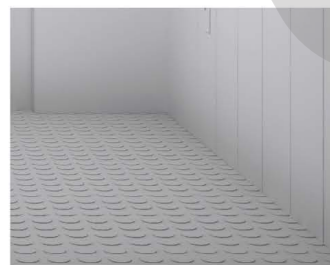

无防撞条装置
No bumper strip

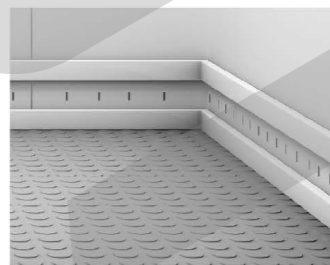

防撞条装置
Bumper strip

注:

本画册所有的颜色、材质、图案选项仅供参考，应以实际合同为准，最新选项变化请咨询我司销售代表。

Note:

Colors, materials and patterns in this catalog is only for reference. Final options shall refer to actual contract. Pls contact our sales representatives for any updated items.

Cabin Ceiling 轿厢吊顶

经典简约, 经久耐用

Being classic and concise, as well as endurable

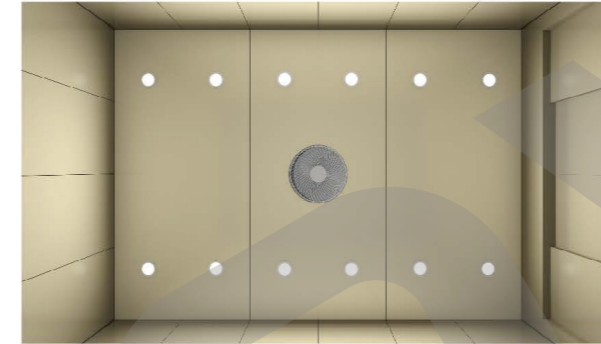

21DD101

钢板喷涂+筒灯+风扇
Painted Steel Plate+Downlight+Fan

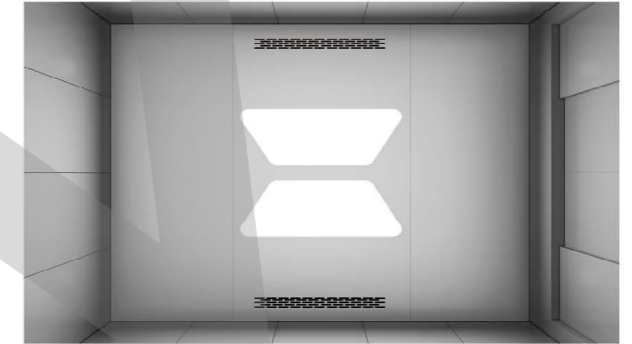

21DD102

钢板喷涂+亚克力+LED照明
Painted Steel Plate+Acrylic+LED ight



21DD103

彩涂钢板+木纹化妆钢板+亚克力+LED照明
Colored Drawing Steel Plate+Wood Grain Steel Plate+Acrylic+LED light

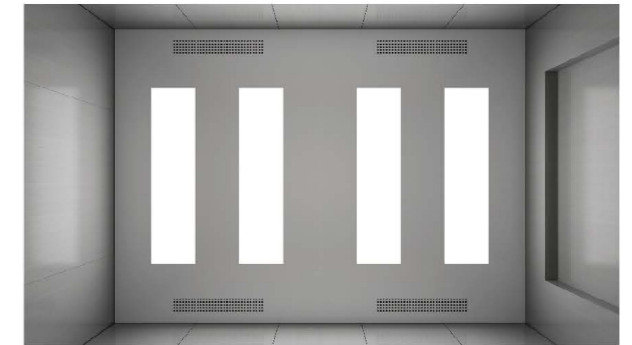

21DD104

钢板喷涂+亚克力+LED照明
Painted Steel Plate+Acrylic+LED light



21DD105

钢板喷涂+筒灯+风扇
Painted Steel Plate+Downlight+Fan



21DD106

发纹不锈钢+筒灯+装饰灯
Hairline St.St.+Downlight+Decorative Light

PERFECT TECHNOLOGY 完美科技



Safety First, Quality is Everything. 安全第一 品质为上

西尼机电载货电梯符合全球安全标准，始终将保障客货安全作为结构设计第一要素。

Siney cargo elevator conforms to the global safety standards, and invariably takes passengers and goods safety as the first element of structural design.

高强度板材折弯成型技术确保轿厢坚固耐用，经过破坏性、可靠性多重测试，可满足不同工况需求。

The bending forming technology of high strength plate ensures the car to be strong and durable. After multiple tests of destructiveness and reliability, it can meet the requirements of different working conditions.

采用四层印制线路结构和SMT贴装技术，超强抗腐蚀涂层适应任何恶劣的工作环境。

Using four layer printed circuit structure and SMT mounting technology, super corrosion resistant coating can adapt to any harsh working environment.

红外线光幕保护 Infrared Light Curtain Protection



通过红外线检测距离地面10mm-1850mm，电梯安全性大幅提升。

Detect 10mm-1850mm above the ground with infrared ray to ensure the safety of passengers or objects when getting in and out and greatly improve elevator safety.

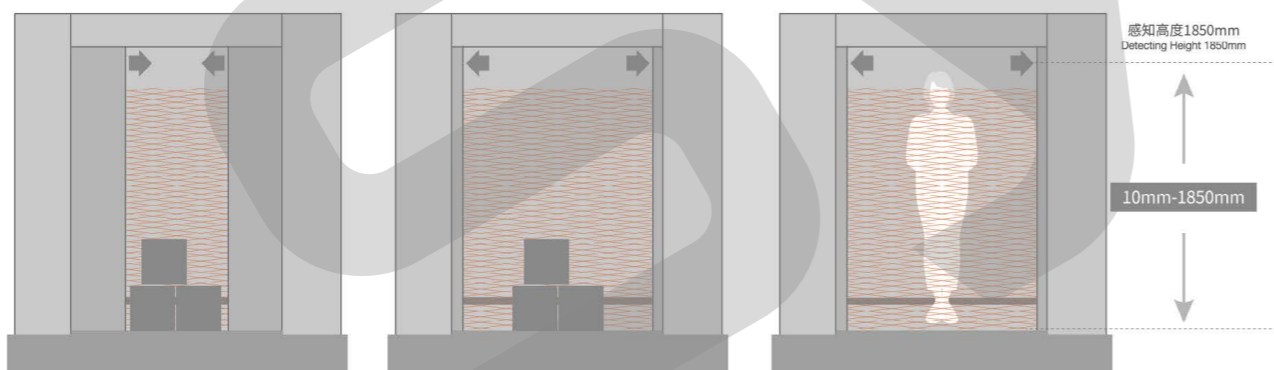

光幕通过红外线光束覆盖整个轿门宽度，以确保人和货物安全进出轿厢。当光幕被阻隔，即检测到有人或物体正进出轿厢，正在关闭的电梯门会迅速自动打开，并保持开门状态。

The light curtain covers the whole width of the car door through the infrared beam to ensure the safety of passengers and goods in and out of the car. When the light curtain is blocked, that is to say, someone or object is coming in and out of the car, the elevator door that is being closed will quickly open automatically and keep the door open.

远程监视功能(选配) Remote Monitoring Function(Optional)



对电梯运行情况进行24小时监测的服务功能。电梯系统通过物联网向监测中心传送电梯运行信息，发生故障或困人时，电梯系统自动向监测平台中心报警，监测中心立即进行分析并登记，监测中心人员还可通过网络平台与被困乘客进行双向视频对话，并进行语音安抚，通知就近维护人员救援。

24-hour monitoring of elevator running conditions is provided. The elevator system will transmit the elevator running signal to monitoring center via IoT. When a fault occurs or passenger get trapped, the elevator system will automatically alert the monitoring center, and the monitoring center will immediately analyze and register. In addition, the monitoring center personnel can also directly talk with passengers through bidirectional video call to comfort the passengers and ask the nearest maintainers to rescue.



超速保护 Overspeed Protection

当运行速度超过额定速度 115% 时，超速保护功能立即启动，使电梯停止运行。

When running speed surpasses 115% of rated speed, overspeed protection will be immediately activated and stop the elevator from running.

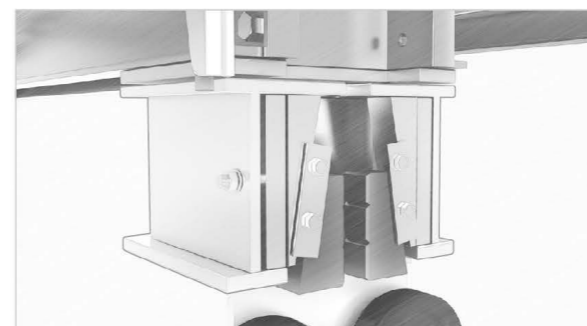

换站停靠 Stop at Other Floors

当电梯因开门受阻而无法正常打开时，电梯会自动关门并运行到邻近的服务层再开门，避免由于某层开门故障而影响电梯的正常运行。

When the elevator cannot open doors normally due to some problems, it will automatically close the door, run to the nearest landing floor and open the door again, to avoid affecting the normal working of the elevator due to a certain floor opening failure.

限速器 Speed Governor

当电梯超过限速器动作速度时，限速器切断安全回路保证电梯停止运行。

When the elevator surpasses the action speed of speed governor, the speed governor will cut off the safety circuit to make sure elevator will stop running.

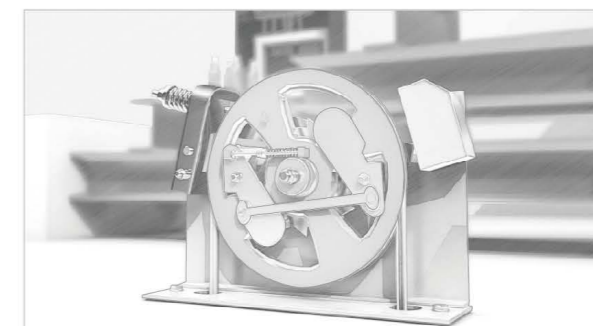

开门保护装置 Door Open Protection Device

可延长开门的时间，以方便特殊乘客或随客货物的上下。

Door open time can be extended to make it convenient for special passengers or passengers with goods to get in and out.

PERFECT TECHNOLOGY 完美科技

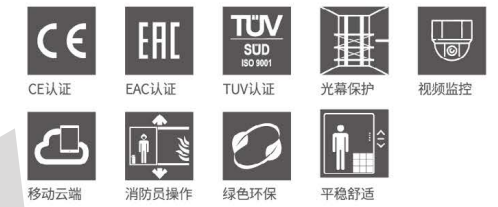

停电应急疏散装置 (选配) Auto Rescue Device(Optional)



当电梯正常运行时突然断电急停时,该装置会迅速动作,驱动电梯低速运行到平层位置,平层后打开门疏散被困乘客。
When sudden power-off happened during normal elevator running, the device will act immediately to drive the elevator to the leveling position at low speed and automatically open the door to evacuate the trapped passengers.

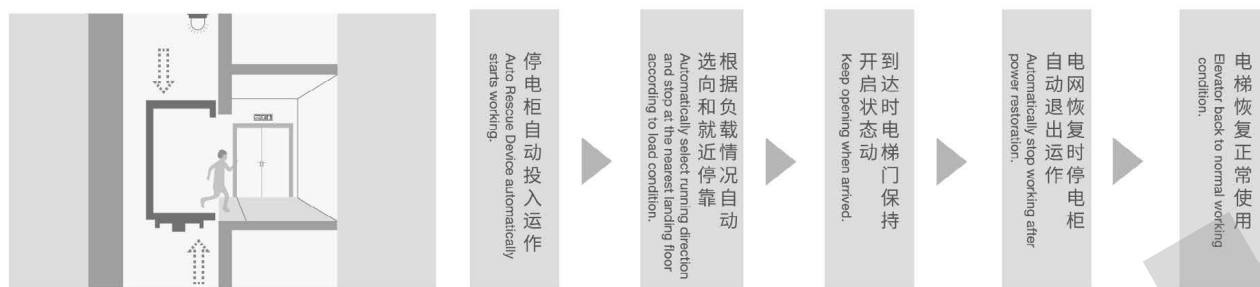

电梯超载保护 Overload Protection

当电梯轿厢的载重大于额定载重量的110%时,电梯保持开门状态并提示超载,只有减轻至额定载重量的110%以内,电梯恢复正常运行。

When cabin capacity is more than 110% of rated load, the elevator will maintain the door open and send voice alarm. Only when the load reduced within 110% rated load will the elevator back to normal working condition.

制动力自检测保护 Braking Force Self-test Protection

防止电机制动器制动力不足,24小时内检测一次,若制动力不足,则禁止运行。

In order to avoid motor brake braking force lacking, it will self-test its braking force within 24 hours. If lacks of braking force, elevator will stop running.

紧急呼叫功能 Emergency Calling Function

可通过轿内对讲机与机房或物业值班室直接对话(有五方通话功能时)。可在轿厢按压操纵箱上的“紧急呼唤”按钮,使轿顶警铃发出响声,通知值班人员。

Passengers can directly talk to the person in the machine room or duty room via cabin interphone (when equipped with 5-way intercom). Press the 'emergency calling' button on COP, the car top alarm bell will ring and inform the people on duty.

UCMP保护装置 UCMP Device

防止在电梯门区开门状态,电梯异常意外移动,将立即启动保护,制停轿厢,保护乘梯人员的安全。

When the elevator makes an unintended movement at the door open area under open status, the device will immediately be activated to maintain the cabin to ensure passengers' safety.

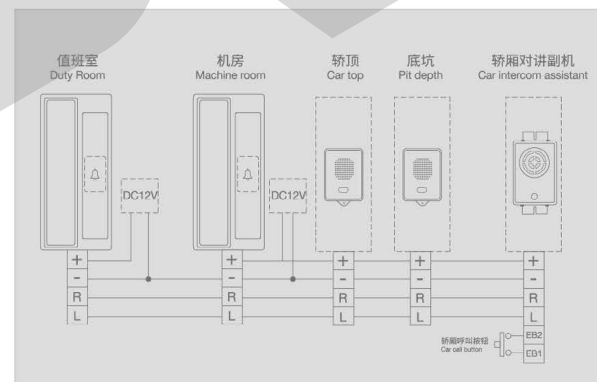
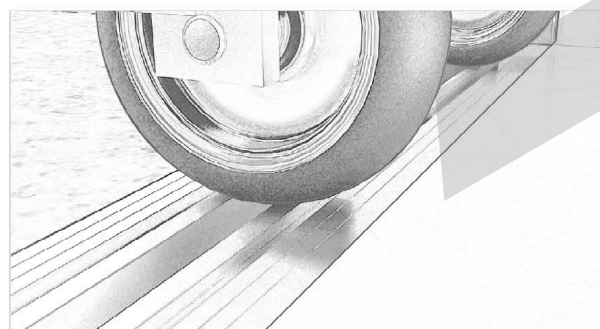

Functions Of Elevator 电梯功能配置

● 标准功能 Standard ○ 选配功能 Optional

全集选控制 Collective selective	自动修正层楼位置信号 Self-correcting floor signal	开门再平层操作 Re level operation when door open	●	
检修运行 Inspection running	锁梯服务 Lock elevator	门旁路功能 Door bypass function	●	
慢速自救运行 Slow running for self-rescue	门区外不能开门的保护 Doors can't be opened outside of landing area	层楼显示字符设置 Floor No. display setting	●	
检测运行 Test running	门光幕保护 Light curtain protection	门开关故障保护 Door switch fault protection	●	
时钟控制 Time control	超载保护 Over current protection	司机操作 Attendant operation	●	
保持开门时间的自动控制 Auto control for door holding time	轻载防捣乱 Anti-nuisance when light load	运行中门锁断开保护 Door lock disconnect protection during running	●	
本层厅外开门 Landing door open	逆向运行保护 Reverse running protection	消防员操作 Firefighter operation	●	
关门按钮提前关门 Close door by close-button in advance	防打滑保护 Anti-sliding protection	轿厢意外移动保护(UCMP) Car accidental movement protection	●	
开门按钮开门 Open door by open-button	终端开关故障 Terminal switch fault	门锁回路监测 Door lock circuit detect	●	
换层停靠 Stop at other floor	终端跃层保护 Terminal overtravel switch protection	运行方向显示 Running direction display	●	
错误指令取消 Cancel wrong commands	接触器触点检测保护 Contactor contact detect protector	独立运行 Independent running	●	
反向时自动消指令 Auto cancel commands when go to reverse direction	主回路故障保护 Main circuit fault protection	轿厢到站钟 Cabin arrival gong	●	
直接停靠 Directly stop	超速保护 Overspeed protection	提前开门操作 Open door in advance	●	
满载直驶 Full load bypass	低速保护 Low speed protection	井道自学习失败诊断 Shaft self-study diagnosis	●	
待梯节能模式 Standby energy-saving mode	平层开关故障保护 Leveling switch fault protection	电机过热保护 Motor overheat protect	●	
自动返基站 Auto return to ground floor	CAN通讯传输 CAN communication transmission	井道层楼数据自学习 Shaft self-study	●	
重复关门 Repeat close door	火灾紧急迫降 Emergency return operation when fire	服务层的任意设置 Service floor setting	●	
故障历史记录 Fault history record	抱闸开关触点检测保护 Brake switch touch inspection protection		●	
安全触板保护 Safety edge protection	副操纵箱操作 Auxiliary operation panel	前后门独立控制 Independent control for front and rear door		○
厅外到站预报灯 Arrival light in landing area	残疾人操纵箱操作 Disabled people operation panel	VIP贵宾层服务 VIP service		○
并联运行 Duplex running	停电应急平层 Auto rescue device	群控运行 Group control		○
语音报站功能 Voice announcement function	分散待梯 Distribute elevator for different waiting position	地震功能 Earthquake function		○
小区监控 Residential district monitor	开门保持按钮操作功能 Door open holding function	一键呼救 One-key help		○

PERFECT

TECHNOLOGY 完美科技



Highly Efficient System, Reliable and Endurable.

高效系统 可靠耐用

高效控制系统全程保障电梯运行，双32位处理器，使数据运算瞬间完成。

The high efficiency control system guarantees the elevator running in the whole running time, and the dual 32-bit processor makes the data operation complete instantly.

CAN总线通讯，使整个控制系统接线简单，数据传输距离远，抗干扰能力强，可靠性高。

CAN bus communication make the whole control system wiring simple and easy and with further data transmission distance, stronger anti-interference capability and higher reliability.

集成化的控制驱动，提供运行效率，增强通讯可靠性。

The integrated control drive guarantees operation efficiency and enhances communication reliability.

新一代永磁同步无齿轮曳引机 New Generation Permanent Magnet Synchronous Gearless Traction Machine

采用新一代永磁同步无齿轮曳引机，选用稀土材料，将同轴传动技术，数字变频技术和群组电脑组合控制将技术充分融合，运行从成本较小，能量散失低。

We adopt a new generation permanent magnet synchronous gearless traction machine which uses rare earth and synchronous axle rotating technology, converges technologies by combining digital variable frequency technology with group computer-integration control, to save running costs and lower energy losses.

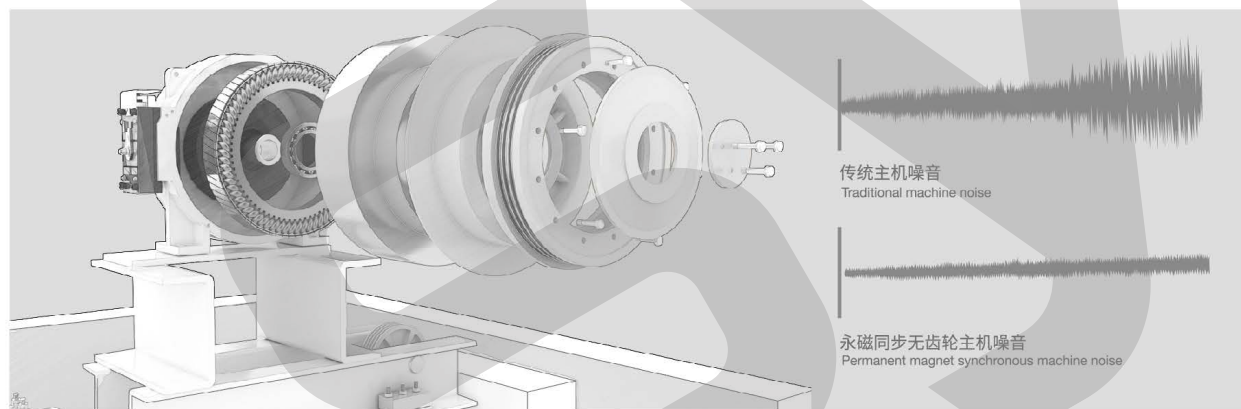

有齿轮曳引机 Geared traction machine

采用有齿轮曳引机，技术先进，品质成熟。采用蜗轮蜗杆传动，传动平稳、传动比大；低速下，曳引扭力大，满足大载重量的情况。

Geared traction machine bears developed technology and high quality. Installed with worm gear, smooth transmission, and big transmission ratio; under low speed, traction machine has more power to meet big load requirement.

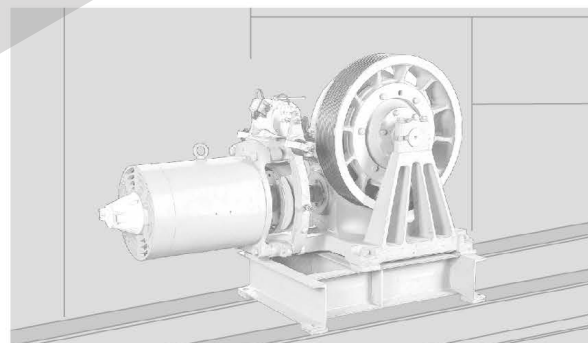

平稳舒适 Stable and Mute

VVVF变频调速系统确保电梯运行中平稳的加速/减速曲线，使平层精度更为精确。控制柜采用了静音接触器，减少噪声污染。

VVVF technology ensures perfect acceleration & deceleration curve during elevator running and reasonable running time between landing floors to make leveling more accurate. Controller adopts mute contact, which reduces noise pollution.

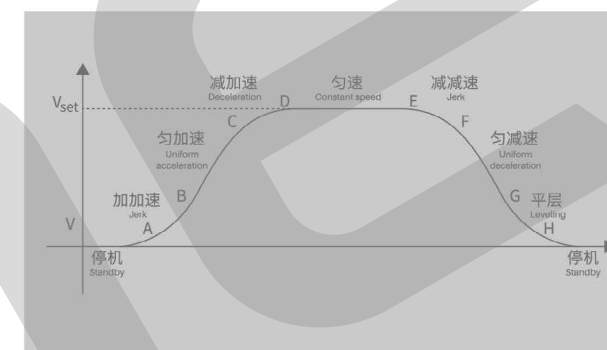

PW控制，负载能力性能强，直接启停，运行平稳舒适。

PW control, strong load capacity performance, direct start and stop, smooth running and comfortable riding.

LED照明 LED Lighting

LED轿内照明装置，光线柔和明亮，热度低，安全、高效、无辐射，有利于长期使用，且系统在电梯空闲时未使用状态下自动熄灭，绿色环保。

高识别度操纵箱 High Definition COP

操纵箱的按钮采用优化设计，对比度强，从而能够避免盲选。防止误乘。采用大按钮，更方便准确。

Buttons on COP are with optimized design and strong contrast, which helps to avoid blind selecting false floors. The big button is used to ensure convenience and accuracy.



语音报站 Voice Announcement

可选语音报站，到站时自动提醒，防止乘客误乘或提示有序退出。

Optional voice announcement will automatically remind when landed to avoid passengers going to false floors.



防滑地板 Anti-skid floor

采用防滑地板，防止雨天有水等情况，进一步保护出行安全。

Anti-skid floor can effectively prevent the slippery on a rainy day, further ensure the safety.

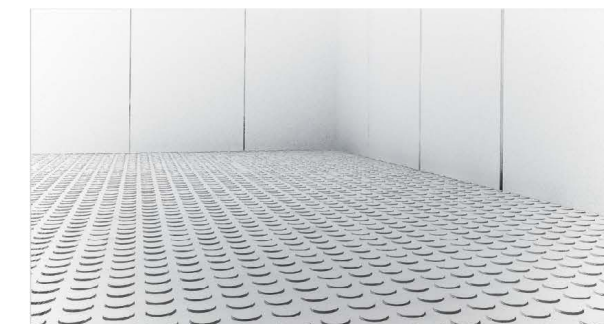

门机层门装置

Landing Door Device

DOOR OPERATOR 变频门机

采用变频门机控制, 开关门速度自由调节, 具有高度的稳定性和出色的灵敏度, 实现了电梯开关门的轻缓、平稳和安全, 方便货物进出。

VF door operator is used to control the elevator door, which enable door open and close speed to adjust automatically and with high stability and perfect sensitivity. It also ensures door open and close to be slow, steady and safe, which is easy for the goods to be in and out.

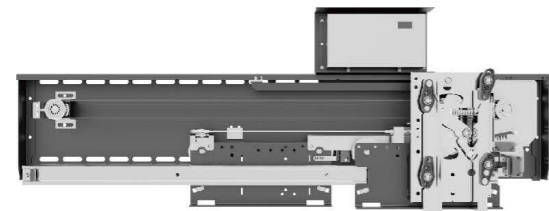
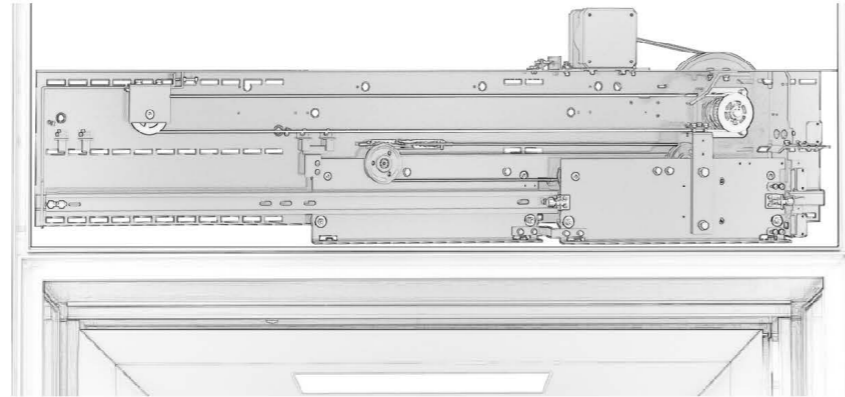

PMA2S-Z
双折式门机装置
Side open door operator

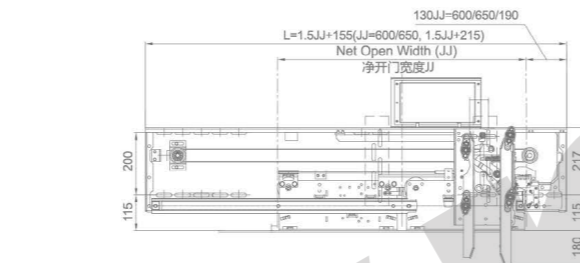

净开门宽 JJ	700	800	900	1000	1100	1200	1300	1400	1500	1600	1700	1800
L	1140	1200	1440	1680	1740	1880	2040	2100	2340	2400	2640	2700

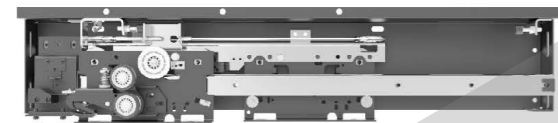

LDA2S-Z
双折式层门装置
Side open landing door device

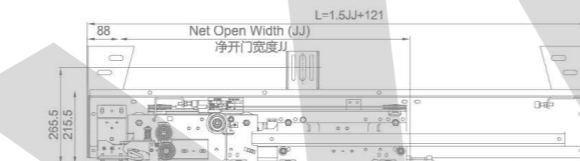

净开门宽 JJ	700	800	900	1000	1100	1200	1300	1400	1500	1600	1700	1800
L	1260	1410	1560	1710	1860	2010	2160	2310	2460	2610	2760	2910

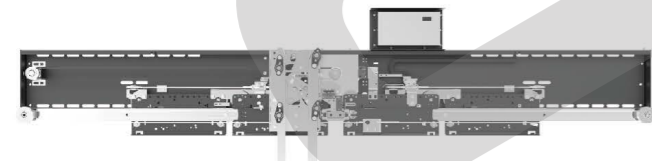

PMA4C-Z
双折中分式门机装置
4-panel center open door operator

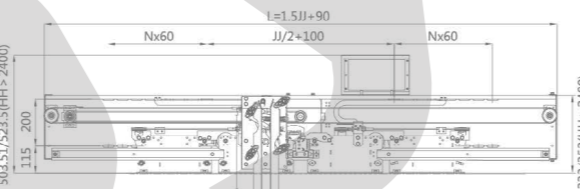

净开门宽 JJ	1200	1300	1400	1500	1600	1700	1800	1900	2000	2100	2200	2300	2400	2500	2600	2700	2800	2900	3000
L	1670	2120	2270	2420	2570	2720	2870	3020	3170	3320	3470	3620	3770	3920	4070	4220	4370	4520	4670



LDA4C-Z
双折中分式层门装置
4-panel center open landing door device



净开门宽 JJ	1200	1300	1400	1500	1600	1700	1800	1900	2000	2100	2200	2300	2400	2500	2600	2700	2800	2900	3000
L	2000	2150	2300	2450	2600	2750	2900	3050	3200	3350	3500	3650	3800	3950	4100	4250	4400	4550	4700

多种开门方式

Multiple Open Ways

Door open way 开门方式



中分开门
Center open door

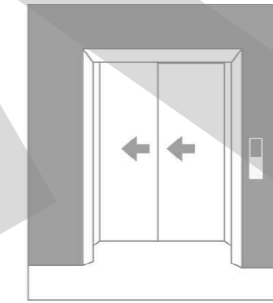

旁开双折门
Side open door

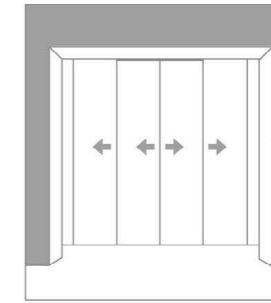

中分双折门
4-panel center open



旁开三折门
3-panel side open door

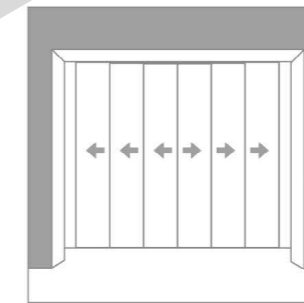

中分三折开门
6-panel center open door

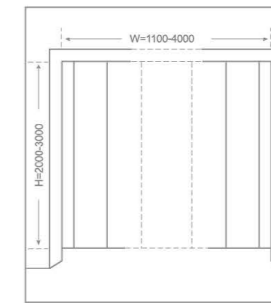

注: 根据实际情况选择开门方式, 详情请咨询我司技术工程师。
Note: Pls select the right open way according to actual site situation. Any problems, pls seek help from our technicians and engineers.

Canbin structure 轿厢结构

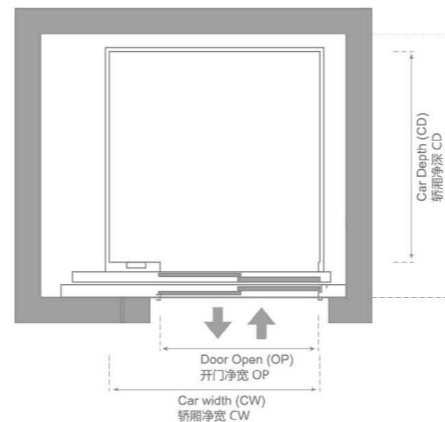

单通门
Single door

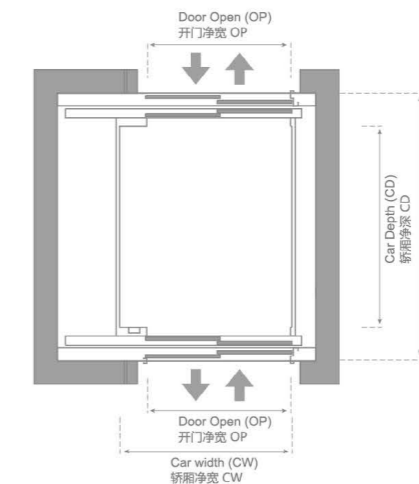

贯通门
Through doors

注: 根据实际情况选择轿厢结构, 如需采用其它轿厢结构, 咨询我司技术工程师。
Note: Pls select the right cabin structure according to actual site situation. If other cabin structure is required, pls contact our technicians and engineers.

注: 图形均为电脑控制, 请以实物为准。
Note: The graphic is drawn by computer, pls refer to real goods.

F2400 Cargo Elevator (MR) F2400有机房无齿轮载货电梯

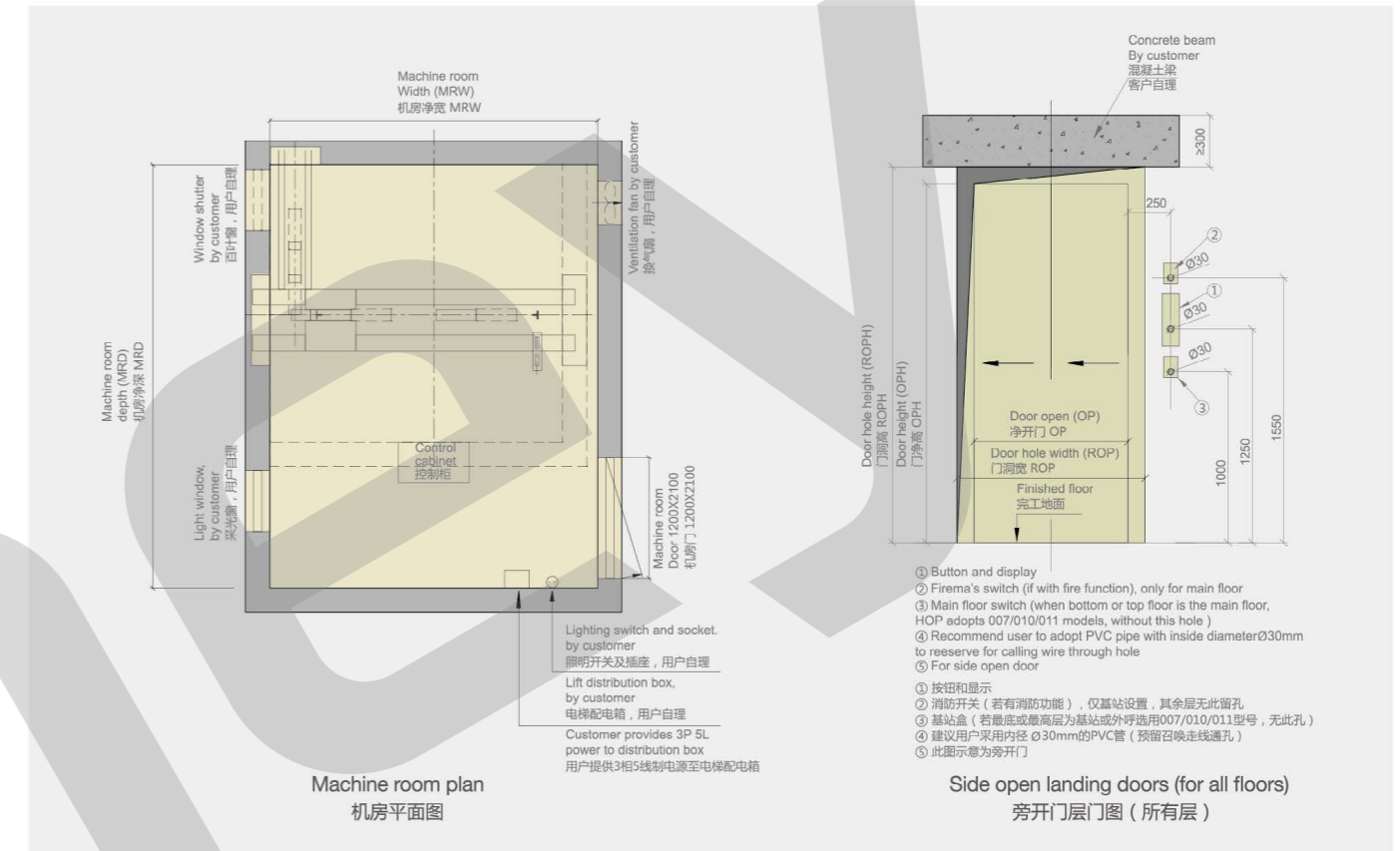
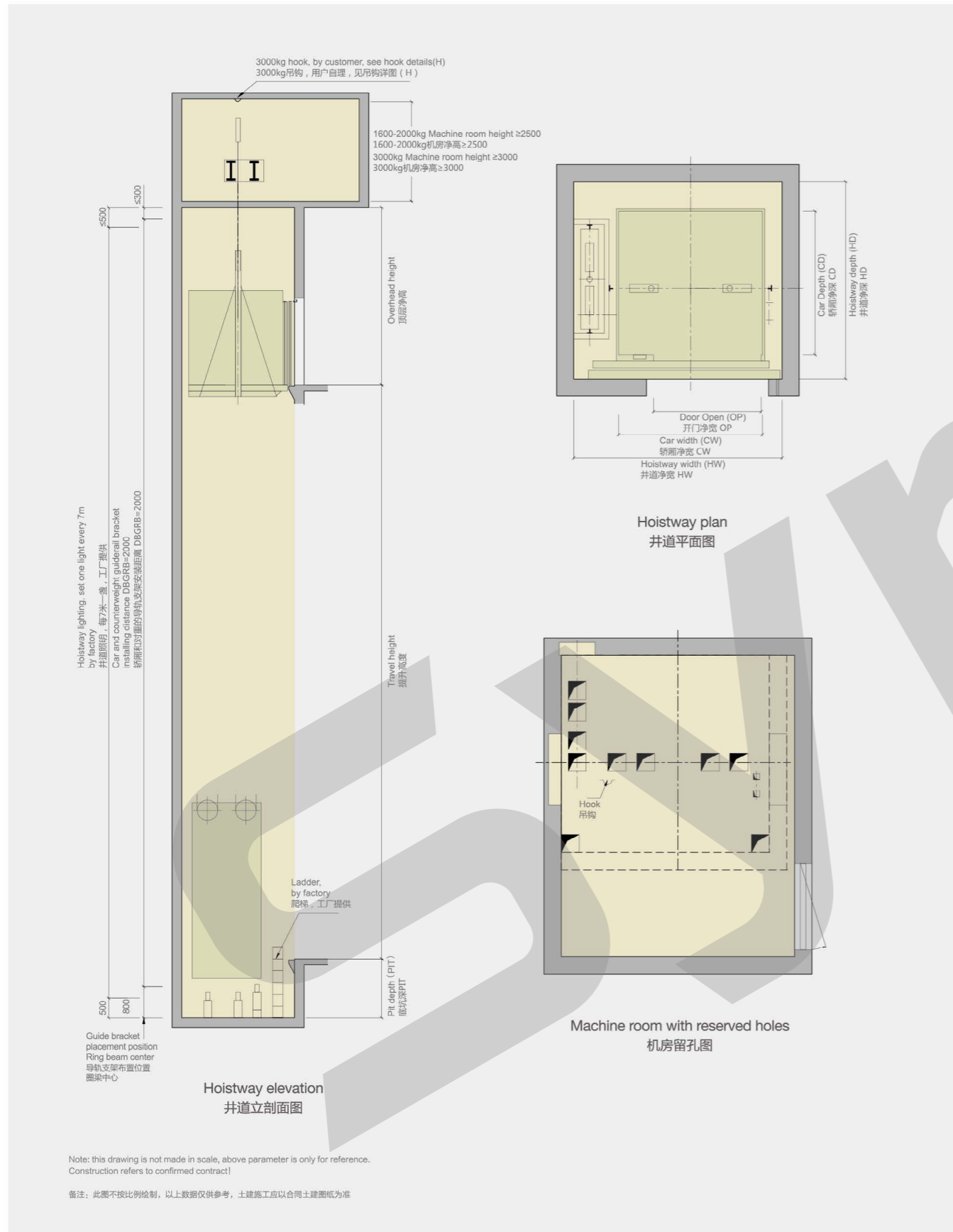

F2400 (单通, 对重侧置) (One cabin door, CWT side placed)

Specification 型号	Rated Load 额定载重 (Kg)	Rated Speed 额定速度 V(m/s)	Traction Ratio 曳引比	Car Dimension Width*Depth*Height 电梯轿厢尺寸 宽*深*高 CW*CD*CH(mm)	Opening Door Width*Height 开门宽*高 OP*OPH(mm)	Hoistway Dimension Width*Depth 井道尺寸 宽*深 SW*HD(mm)	Hoistway Overhead 井道顶部高度 (标准) OH(mm)	Pit Depth 底坑深度 (标准) PIT(mm)	Machine Room Dimension Width*Depth 机房尺寸 宽*深 MRW*MRD(mm)
F2400	1600	0.5	4:1	1700X2000X2300	1300X2100	2600X2750	4500	1500	2950X4150
		0.63					4500	1500	
		1					4500	1500	
	2000	0.5		2000X2000X2300	1500X2100	2900X2750	4500	1500	3250X4150
		0.63					4500	1500	
		1					4500	1500	
3000	0.5	2000X2800X2300	1800X2100	3300X3300	4500	1500	3300X3300		
	0.63				4500	1500			
	1				4500	1500			

备注:
Note

1. 以上参数为单通有机房无齿轮4:1货梯, 1600KG-2000KG开门方式为旁开双折, 3000KG开门方式为中分双折, 特殊轿厢, 开门要求, 轿厢贯通, 上表未列出载重的有机房货梯请咨询我司电梯技术部。
2. 当井道实际土建参数超出上表参数时, 请咨询我司电梯技术部。
1. Above specifications are for single door machine room gearless 4:1 cargo elevator. For load capacity 1600Kg-2000Kg door open will be side open; 3000Kg will be 4-panel center open. Regarding special cabin, open way, through door or any load capacity not listed, pls contact our technician department.
2. If actual shaft specifications exceed above listed specifications, pls contact our technician department.

F2403 MRL Gearless Cargo Elevator

F2403无机房无齿轮载货电梯

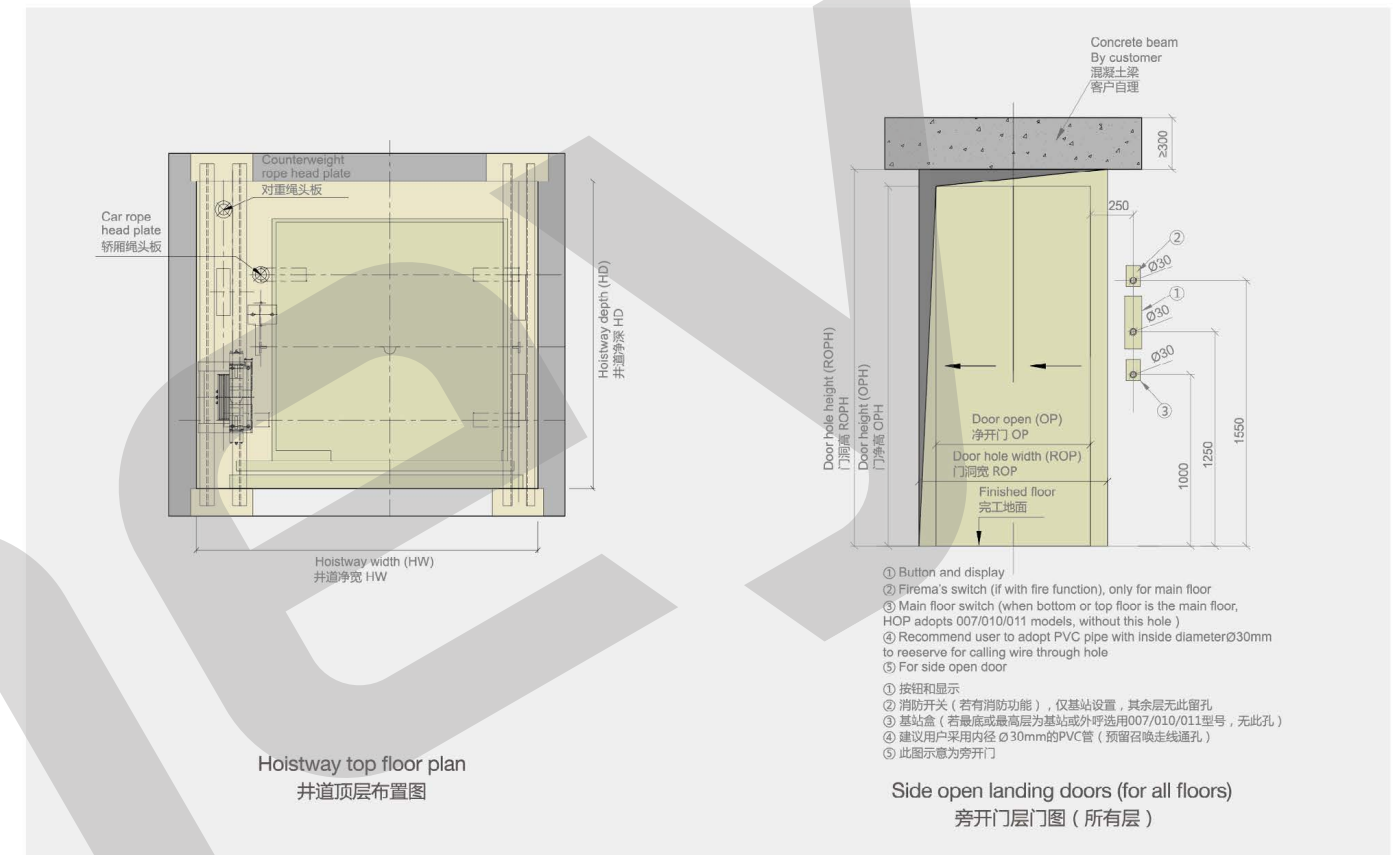
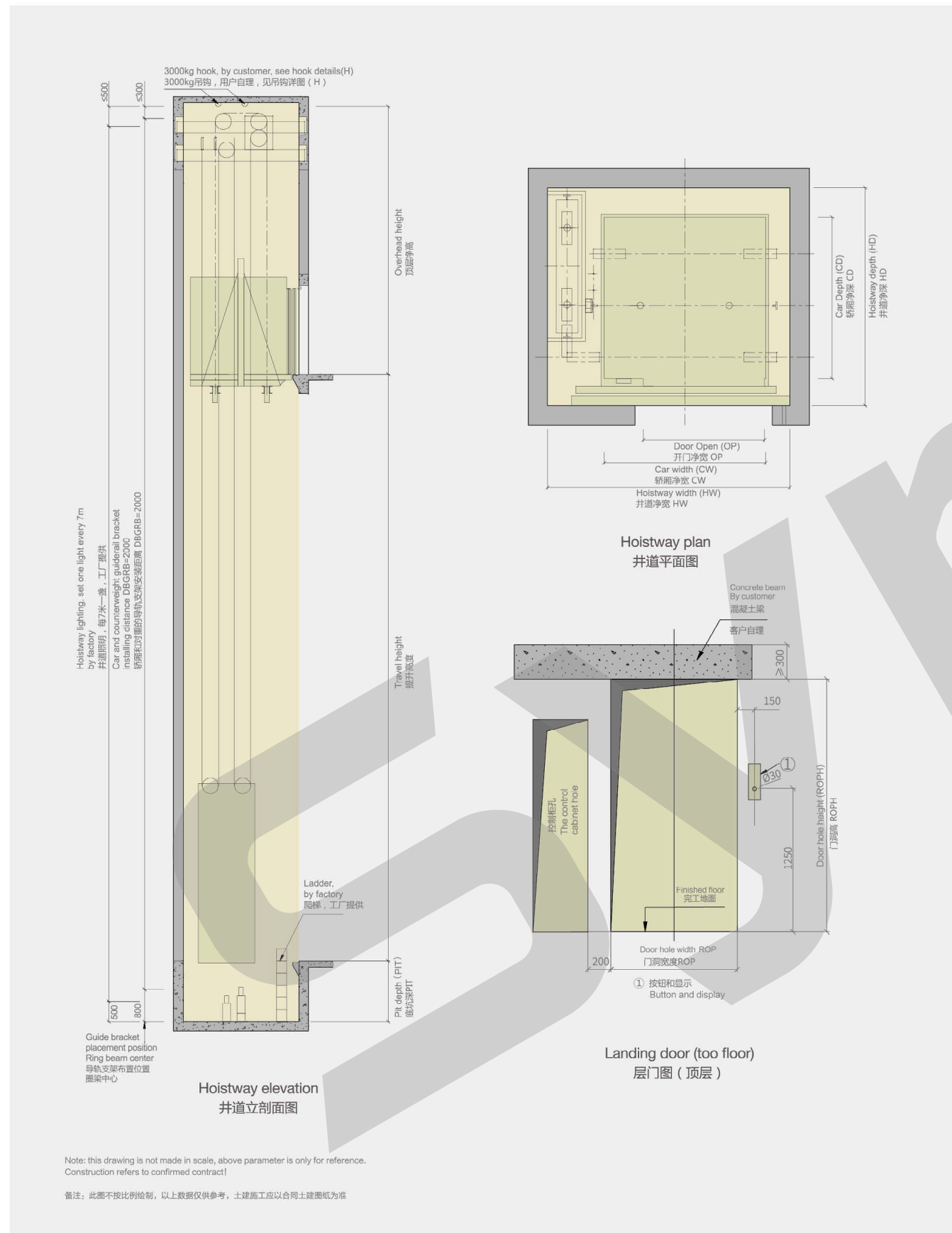

F2403(单通,对重侧置) (One cabin door, CWT side placed)

Specification 型号	Rated Load 额定载重 (Kg)	Rated Speed 额定速度 V(m/s)	Traction Ratio 曳引比	Car Dimension Width*Depth*Height 电梯轿厢尺寸 宽*深*高 CW*CD*CH(mm)	Opening Door Width*Height 开门宽*高 OP*OPH(mm)	Hoistway Dimension Width*Depth 井道尺寸 宽*深 SW*HD(mm)	Hoistway Overhead 井道顶层高度 (标准) OH(mm)	Pit Depth 底坑深度 (标准) PIT(mm)
F2403	1600	0.5	4:1	1700X2000X2300	1300X2100	2700X2700	4500	1600
		0.63					4500	1600
		1					4500	1700
	2000	0.5		2000X2000X2300	1500X2100	3000X2700	4500	1600
		0.63					4500	1700
		1					4500	1700
3000	0.5	2000X2800X2300	1800X2100	3350X3300	5200	1600		
	0.63				5200	1600		
	1				5200	1700		

备注: Note

1. 以上参数为单通无机房无齿轮4:1货梯, 1600KG-2000KG开门方式为旁开双折, 3000KG开门方式为中分双折。特殊轿厢、开门要求、轿厢速度、上表未列出载重的无机房货梯请咨询我司电梯技术部。
2. 当井道实际土建参数超出上表参数时, 请咨询我司电梯技术部。
1. Above specifications are for single door machine roomless gearless 4:1 cargo elevator. For load capacity 1600Kg-2000Kg door open will be side open; 3000Kg will be 4-panel center open. Regarding special cabin, open way, through door or any load capacity not listed, pls contact our technician department.
2. If actual shaft specifications exceed above listed specifications, pls contact our technician department.

F2407 MR Geared Cargo Elevator

F2407有机房有齿轮载货电梯

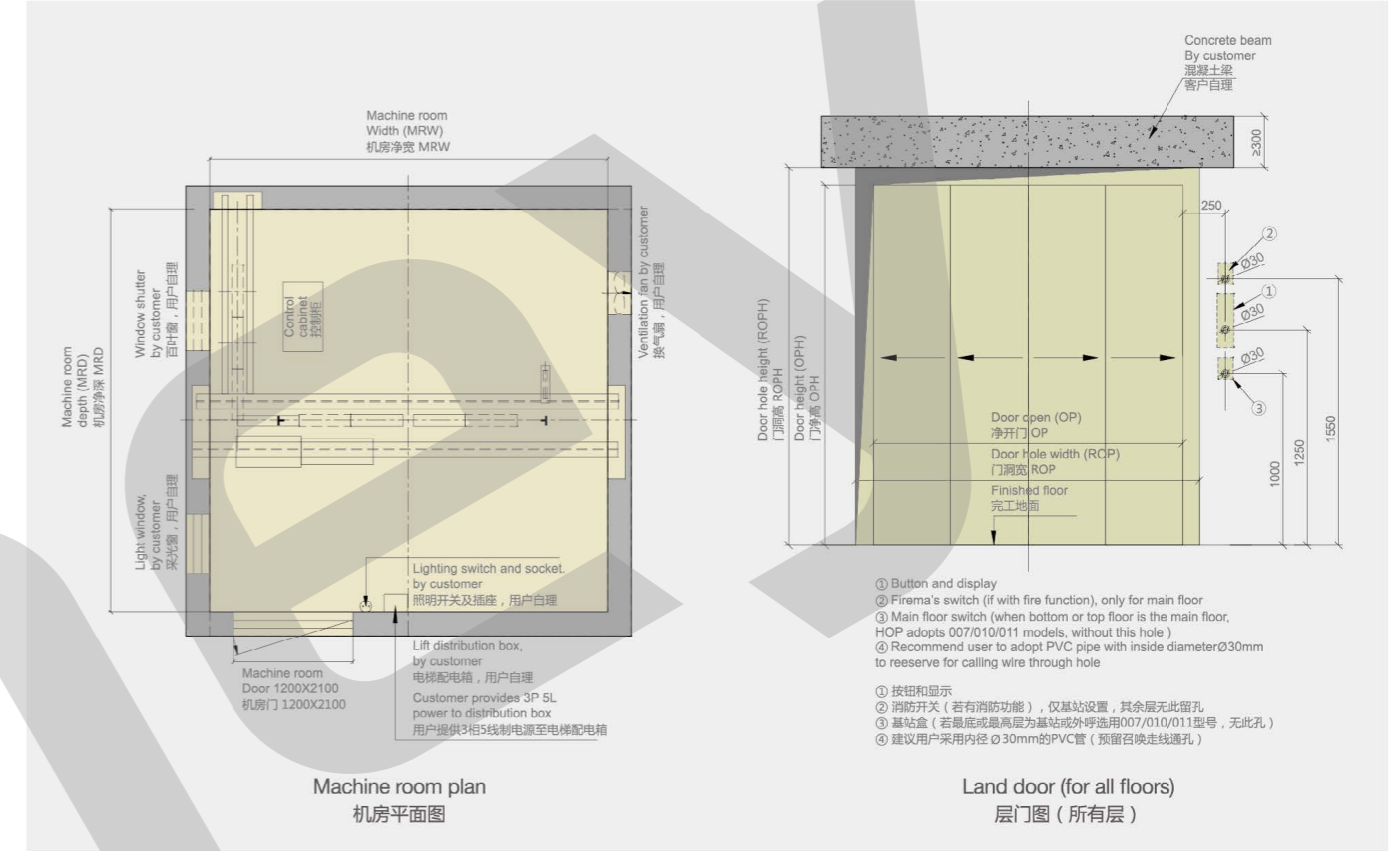
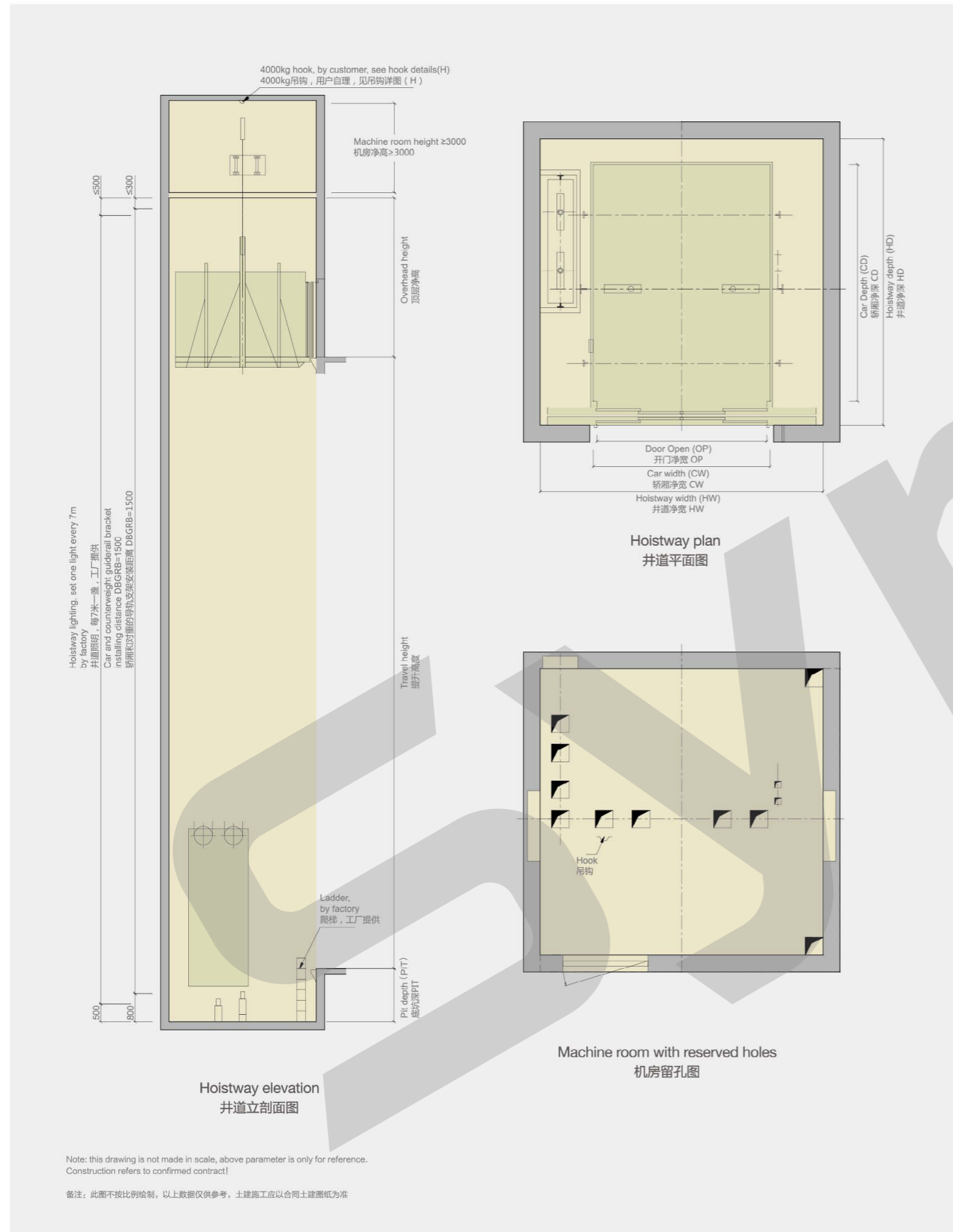

F2407 (单通,对重侧置) (One cabin door, CWT side placed)

Specification 型号	Rated Load 额定载重 (Kg)	Rated Speed 额定速度 V(m/s)	Traction Ratio 曳引比	Car Dimension Width*Depth*Height 电梯轿厢尺寸宽*深*高 CW*CD*CH(mm)	Opening Door Width*Height 开门宽*高 OP*OPH(mm)	Hoistway Dimension Width*Depth 井道尺寸宽*深 SW*HD(mm)	Hoistway Overhead 井道顶层高度 (标准) OH(mm)	Pit Depth 底坑深度 (标准) PIT(mm)	Machine Room Dimension Width*Depth 机房尺寸宽*深 MRW*MRD(mm)
F2407	4000	0.25	4:1	2300X3100X2300	2000X2100	3700X3700	4900	1500	3700X3700
		0.5					4900	1500	
	5000	0.25		2500X3350X2300	2400X2100	4000X4050	4900	1500	4000X4050
		0.5					4900	1500	
	7000	0.25		2900X4000X2300	2400X2100	4300X4600	4900	1500	4300X4600
		0.5					4900	1500	

备注: Note

- 以上参数为单通有机房有齿轮4:1货梯, 开门方式为中分双折. 特殊轿厢、开门要求、轿厢贯通、上表未列出载重的有机房货梯请咨询我司电梯技术部。
- 当井道实际土建参数超出上表参数时, 请咨询我司电梯技术部。
- Above specifications are for single door machine room geared 4:1 cargo elevator, whose open way 4-panel center open. Regarding special cabin, open way, through door or any load capacity not listed, pls contact our technician department.
- If actual shaft specifications exceed above listed specifications, pls contact our technician department.

THJ MR Geared Cargo Elevator

THJ有机房有齿轮载货电梯

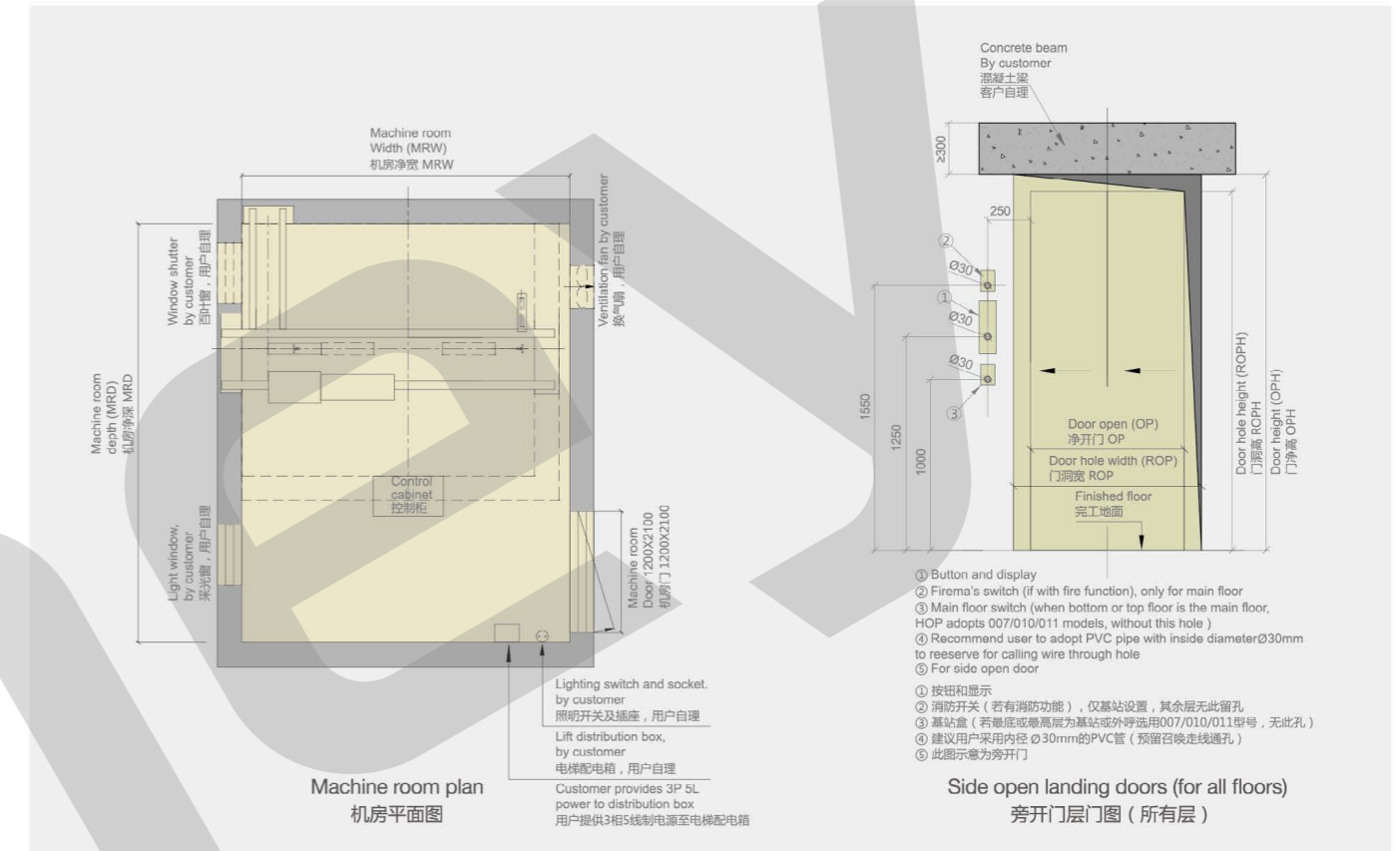
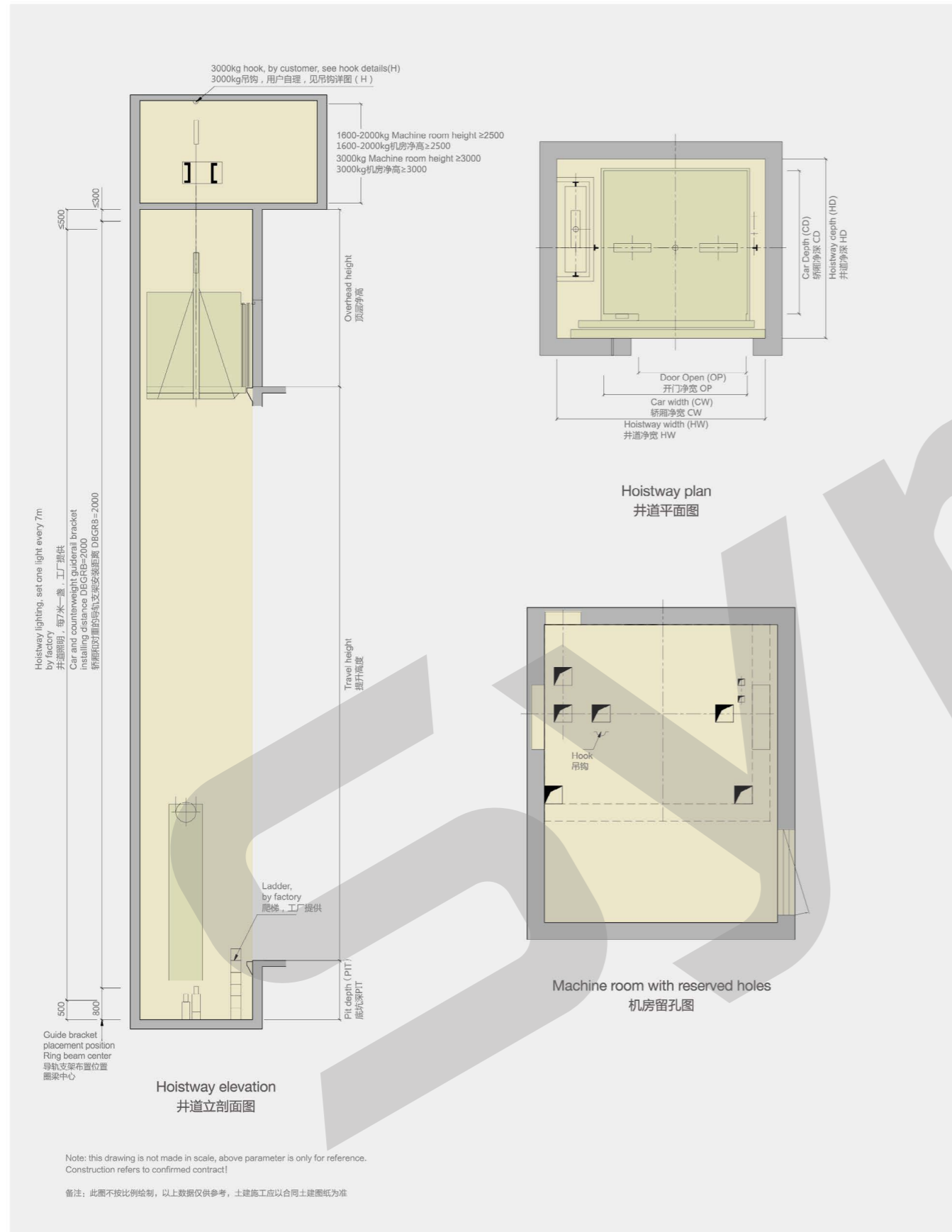

THJ(单通, 对重侧置) (One cabin door, CWT side placed)

Specification 型号	Rated Load 额定载重 (Kg)	Rated Speed 额定速度 V(m/s)	Traction Ratio 曳引比	Car Dimension Width*Depth*Height 电梯轿厢尺寸*宽*深*高 CW*CD*CH(mm)	Opening Door Width*Height 开门宽*高 OP*OPH(mm)	Hoistway Dimension Width*Depth 井道尺寸宽*深 SW*HD(mm)	Hoistway Overhead 井道顶层高度 OH(mm)	Pit Depth 底坑深度 (标准) PTT(mm)	Machine Room Dimension Width*Depth 机房尺寸宽*深 MRW*MRD(mm)
THJ	1600	0.5	2:1	1700X2000X2300	1300X2100	2800X2500	4500	1500	2950X4150
		0.63					4500	1500	
		1					4500	1500	
	2000	0.5		2000X2000X2300	1500X2100	2900X2500	4500	1500	3250X4150
		0.63					4500	1500	
		1					4500	1500	
3000	0.5	2000X2800X2300	1800X2100	3300X3400	4500	1500	3300X3400		
	0.63				4500	1500			

备注:
Note

1. 以上参数为单通有机房有齿轮2:1货梯, 1600KG-2000KG开门方式为旁开双折, 3000Kg开门方式为中分双折。特殊轿厢、开门要求、轿厢贯通、上表未列出载重的有机房货梯请咨询我司电梯技术部。
2. 当井道实际土建参数超出上表参数时, 请咨询我司电梯技术部。
1. Above specifications are for single door machine room geared 2:1 cargo elevator. For load capacity 1600Kg 2000Kg door open will be side open; 3000Kg will be 4-panel center open. Regarding special cabin, open way, through door or any load capacity not listed, pls contact our technician department.
2. If actual shaft specifications exceed above listed specifications, pls contact our technician department.

C2501 MR Car Elevator C2501有机房汽车电梯

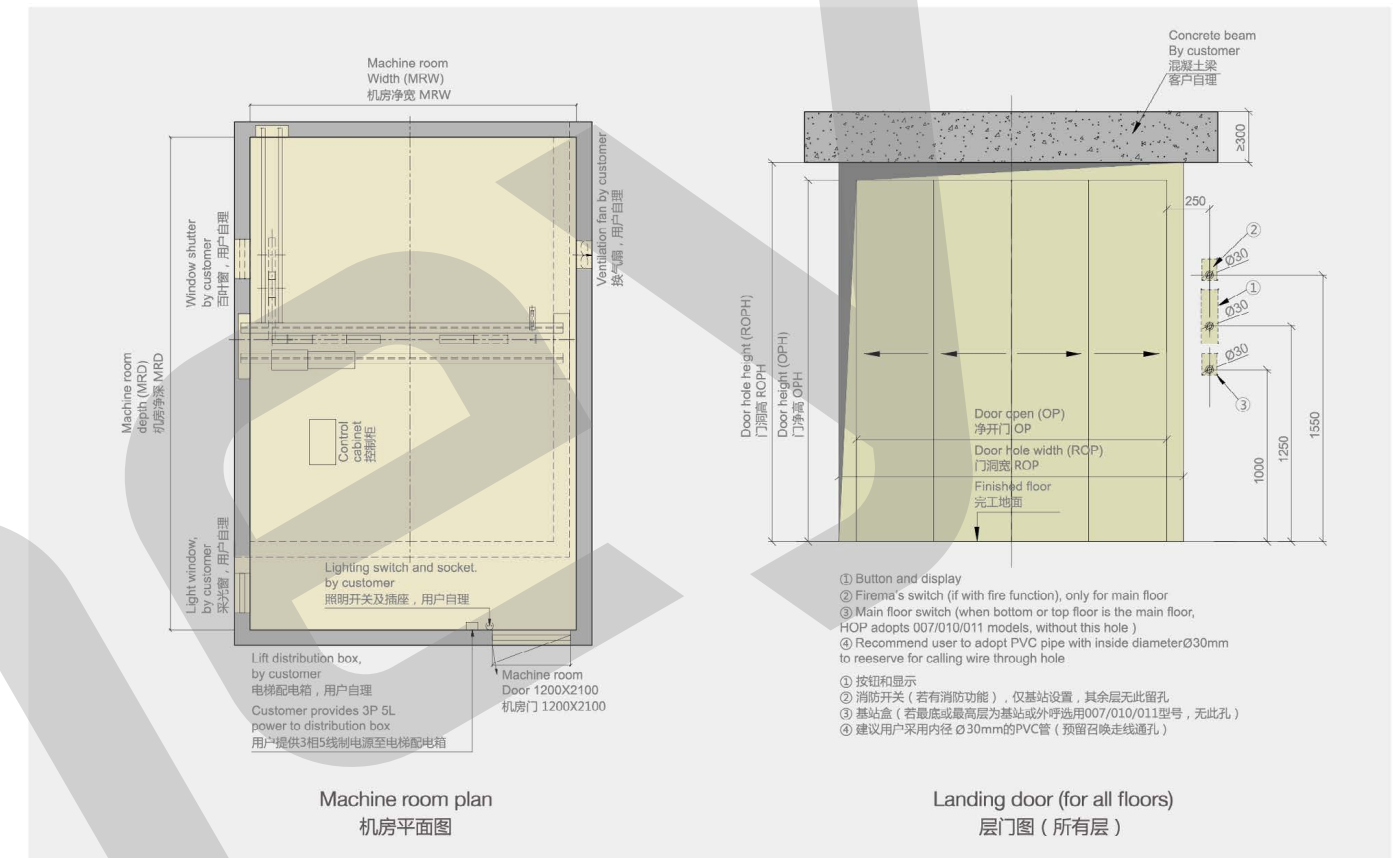
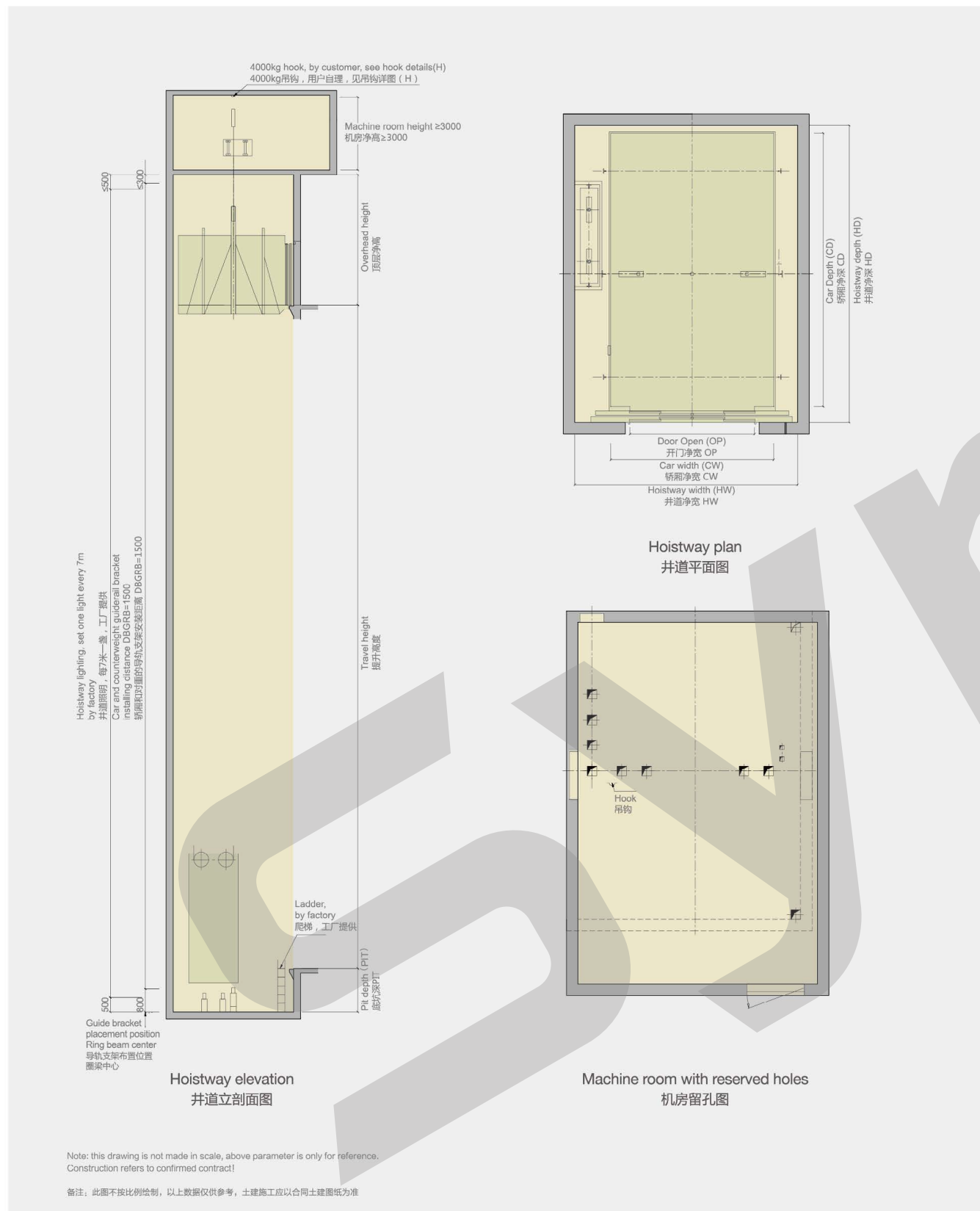

C2501(单通,对重侧置) (One cabin door, CWT side placed)

Specification 型号	Rated Load 额定载重 (Kg)	Rated Speed 额定速度 V(m/s)	Traction Ratio 曳引比	Car Dimension Width*Depth*Height 电梯轿厢尺寸 宽*深*高 CW*CD*CH(mm)	Opening Door Width*Height 开门宽*高 OP*OPH(mm)	Hoistway Dimension Width*Depth 井道尺寸 宽*深 SW*HD(mm)	Hoistway Overhead 井道顶层高度 (标准) OH(mm)	Pit Depth 底坑深度 (标准) PIT(mm)	Machine Room Dimension Width*Depth 机房尺寸 宽*深 MRW*MRD(mm)
C2501	3000	0.25	4:1	2500X5700X2500	2400X2400	4000X6200	4900	1500	4350X7550
		0.5					4900	1500	
	4000	0.25		2900X5700X2500	2400X2400	4300X6200	4900	1500	4650X7550
		0.5					4900	1500	
	5000	0.25		3400X5700X2500	2600X2400	4650X6200	4900	1500	5000x7550
		0.5					4900	1500	

备注:
Note

1. 以上参数为单通有机房有齿轮4:1汽车电梯, 开门方式为中分双折。特殊轿厢、开门要求、轿厢贯通、上表未列出载重的有机房汽车电梯请咨询我司电梯技术部。
2. 当井道实际土建参数超出上表参数时, 请咨询我司电梯技术部。
1. Above specifications are for single door machine room geared 4:1 car elevator, whose open ways is 4-panel center open. Regarding special cabin, open way, through door or any load capacity not listed, pls contact our technician department.
2. If actual shaft specifications exceed above listed specifications, pls contact our technician department.